



UNIQUE office furniture

N Wood Co., Ltd.

We are making office furniture that emphasizes smart office concept and functionality. It is a company that researches and develops to create an efficient office environment by interpreting spatial analysis, changing office equipment and business forms. We will imagine and think in order to make office furniture more convenient and practical with user-centered thinking, and we will return with the trend that suits the times.

A promise that can be kept and a company that keeps promises to customers! We promise to be N Wood Co., Ltd. that thinks about people by activating corporate R & D and supplies the best products with design development and professional human resources and technology facilities.



N WOOD PROMISES TO CUSTOMERS

New trends through continuous research and development and creative thinking.
Professional spirit to do our best every product.
Communication based on trust.

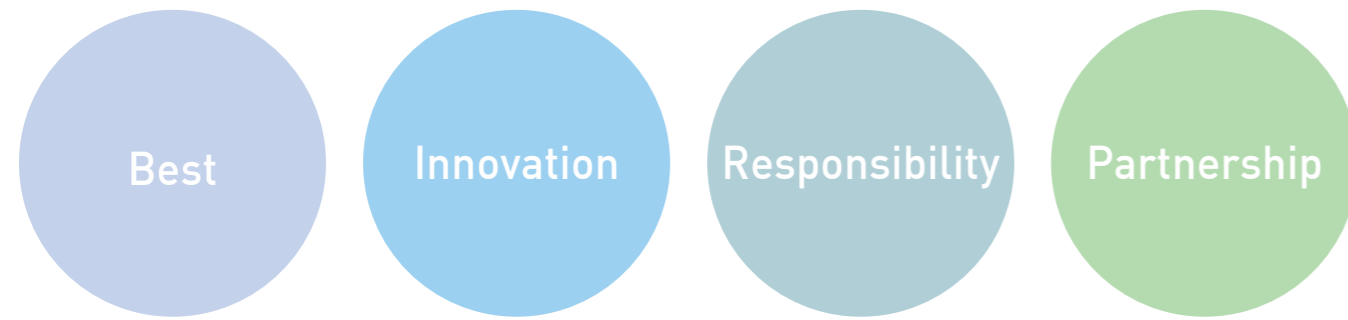

OFFICE CONSULTING SYSTEM

In order to make more efficient office environment through analysis and interpretation of space, N Wood is planning and designing by professional consultant to analyze data such as space utilization analysis and survey and make effective use of given space.



STEP.1

Analysis of the current office furniture

Survey of Current Business Space configuration and identify moving into departmental business



STEP.2

Spatial analysis and Layout

Identify your needs
Major issue diagnosis
Interdepartmental Communication
Analysis Moving Line and Concept Layout Plan



STEP.3

Simulation Design

Layout design
3D image design
Detailed spatial plan design



STEP.4

Deduction of Office Environment Improvement Plan

N Wood creates a healthy office environment

Furniture is most often encountered by people at work and school. Office workers work 1/3 of the day in the office. For those who are tired of the stress of work, N Wood promises to make the healthiest furniture with the best Eco-friendly materials to create a healthy office environment.

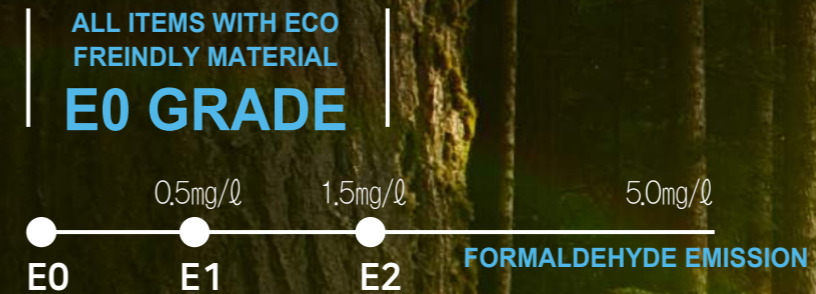



CONTENTS

OFFICE FURNITURE

	12
VENTURE Series	26
MOVING DESK Series	34
CHALLENGE Series	54
SQUARE Series	62
SOLOMON Series VIBE	80
DESK Series BASIC	92
DESK Series TOP	102
DESK II Series	110
CABINET Series	116
LOCKER Series	120
CONFERENCE TABLE	

PARTITION

30T SCAPE Series	136
60T BLOCK Series 유리	140
≡60T BLOCK Series 엠	142
비45T BLOCK Series FX2	144

CHAIR

EXECUTIVE CHAIR Series	148
OFFICE CHAIR Series	152
CONFERENCE CHAIR Series	160

EXECUTIVE FURNITURE

	164
GENERAL Series	172
MATE Series	178
TONO Series MAJESTY Series EFFORT Series	190
	196

SOFA

EXECUTIVE SOFA Series	200
LOBBY SOFA Series	212

EDUCATION

UNIQUE Series	224
CHIC Series	228
MILD Series	232
LIBRARY Series	234
COMPUTER DESK Series	248
PERSONAL LOCKER Series	254
CLASSROOM Series	258
DORMITORY Series	264
LABORATORY Series	270
HOSPITAL Series	280



OFFICE FURNITURE

Office furniture that can maximize the work efficiency of employees. In addition, it protects each member's professional and independent work areas, stimulates creativity and motivates them, while maximizing smooth communication between members.

VENTURE Series	12
MOVING DESK Series	26
CHALLENGE Series	34
SQUARE Series	54
SOLOMON Series	62
VIBE DESK Series	80
BASIC DESK Series	92
TOP DESK II Series	102
CABINET Series	110
LOCKER Series	116
CONFERENCE TABLE	120

OFFICE FURNITURE

- Office Design Furniture
- Office
- Executive
- Library
- Computer Desk
- Personal Locker
- Chair



INVESTMENT AND BUSINESS START-UP

Co-working Space Series 'Venture' seeks to be a foundation for success. We will produce a working space with a simple and compact design for customer.



Co-working Space means a place where various people from different positions and occupations come together to share the space and share knowledge and know-how beyond the space through natural contact and communication. Co-working is a type of work that is appropriate for the age of knowledge and information. It is characterized by the fact that anyone can collaborate and share knowledge and experience.

VENTURE series

N Wood 'Venture' is creating a unit bar that can realize personal storage, common space, and various types of work.





Plasma Sterilizer

Sterilizes more than 99% of fungi and various viruses that can be fatal to humans

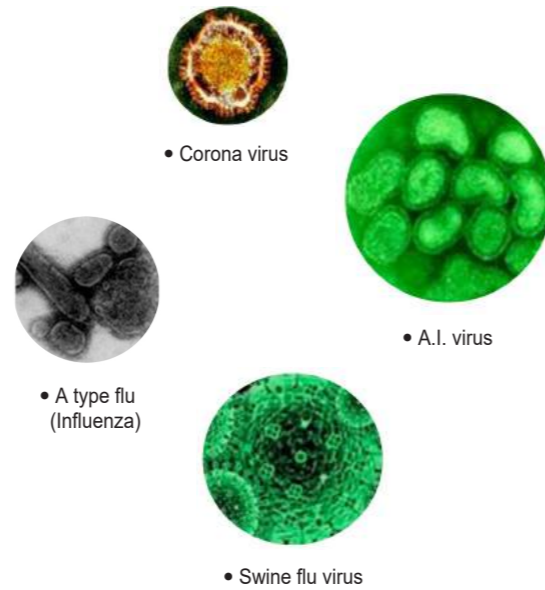

Function

- Power : On/Off
- TEMP-L : MID TEMP AIR FLOW (40°C~45°C)
- TEMP-H : HIGH TEMP AIR FLOW (50°C~55°C)
- TIMER : OPERATING TIME (3/7/12/24 HOURS)
- PLASMA : S-Plasma Sterilization(0.4W / 1.5m²)
- AUTO : TEMP-H + TIME(24h) + PLASMA(Sterilization)

Color



Plasma / Phytoncide



Equipped with storage furniture, such as a closet
 Eco-friendly product for sterilization and deodorization as well as simple dry, Atopic dermatitis and allergy prevention Built-in Super Plasma Ion Generator
 Custom built-in home appliance deodorization and mold suppression for all storage furniture

Test Report

Inspection Institution	Item	Result
Retroscreen (British Clinical Trial Institution)	Avian Flu (H5N1) Virus	99.90% Removed
BAF (British Allergy Association)	Mite carcass, dog and cat fur (Allegen)	Effect Verification / BAF Seal
RTI (American Allergy Research Institute)	Mite carcass, dog and cat fur (Allegen)	Effect Verification
	Influenza Virus Type A Flu	99.70% Removed
	Blue mold	98.40% Removed
	Yeast mold	96.40% Removed
	Cladosporium / mold	96.40% Removed
	Staphylococcus aureus	98.90% Removed
	Cocci / bacteria	99.96% Removed
	MRSA antibiotic resistant pathogen	99.86% Removed
		99.99% Removed
Kitasato Medical Center (Japan)	Coronavirus (SARS virus)	99.60% Removed
Yonsei University	Influenza Virus Type A Flu	99.60% Removed
Chungnam National University	Swine flu (N1N1) virus	99.90% Removed
Korea Consumer Science Research Center	Staphylococcus Aureus / E. Coli	99.99% Removed
Shanghai Medical Research Center	Indoor bacteria	90.00% Removed
Seoul Toxic Research Institute	Animal Toxicity Test	Non-toxic
	Active hydrogen atom identification	Active hydrogen generated
	OH-radical (hydroxyl group)	Free radical neutralization



DETAIL

01_ Efficient internal storage

Spacious interior space easily accommodated, such as a laptop or a variety of documents, and can be stored for various office supplies, personal items.

02_ Plastic storage box

Apply a plastic storage box inside to facilitate convenient storage and transport personal items.

03_ Business card holder and electronic key

The business card holder allows you to choose your personal nameplate function and a variety of locks for the electronic and dial keys.

※Business card holder is optional



KEY SYSTEM



Electronic Key



Dial Key



LOCKER

Locker for 3 (Electronic Key)
CWLK043EK W400×D570×H1994



Locker for 3 (Dial Key)
CWLK043DK W400×D570×H1994

Locker for 4 (Electronic Key)
CWLK044EK W400×D570×H1994



Locker for 4 (Dial Key)
CWLK044DK W400×D570×H1994

Locker for 6 (Electronic Key)
CWLK086EK W800×D570×H1994



Locker for 6 (Dial Key)
CWLK086DK W800×D570×H1994

Locker for 8 (Electronic Key)
CWLK088EK W800×D570×H1994



Locker for 8 (Dial Key)
CWLK088DK W800×D570×H1994

Plasma Wardrobe
CWLK085PZ W800×D570×H1994
CWLK105PZ W1000×D570×H1994



BASIC COLOR





DETAIL

01_ Top pocket

The top plate is designed with a dual structure and there are pockets to store your personal items for a while.

02_ Round top treatment

Emphasizes smooth lines with rounded tops

03_ Simple legs

The simplicity and footrest functionality of the lower steel legs is a solid undercarriage to help with reinforcement.

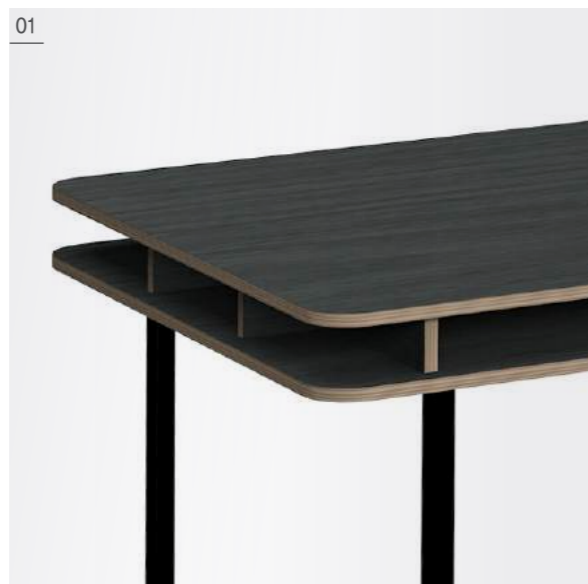

DESK

Desk

- DS112W** W1200×D700×H720
- DS114W** W1400×D700×H720
- DS116W** W1600×D700×H720



Desk

- DS112B** W1200×D700×H720
- DS114B** W1400×D700×H720
- DS116B** W1600×D700×H720



CONFERENCE TABLE

Conference Table

- CT118HW** W1800×D900×H1000



Conference Table

- CT118HB** W1800×D900×H1000



Conference Table

- CT012HW** W1200×D600×H1000
- CT014HW** W1400×D600×H1000
- CT016HW** W1600×D600×H1000



Conference Table

- CT012HB** W1200×D600×H1000
- CT014HB** W1400×D600×H1000
- CT016HB** W1600×D600×H1000



Conference Table

- CT0129W** W1200×D900×H720
- CT0149W** W1400×D900×H720



Conference Table

- CT0129B** W1200×D900×H720
- CT0149B** W1400×D900×H720





DETAIL

01_ Easy Assembly
 Easy assembly makes it easy for anyone to assemble.

02_ Front and rear neat finish
 The housing for assembly is designed to be invisible on the front and back.

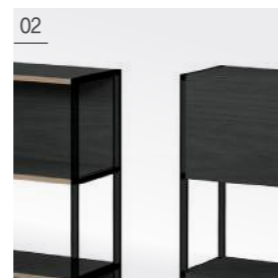

BOOKSHELF

3S Open
BS083W W800×D300×H1060
BS083B W800×D300×H1060



BS083W **BS083B**

3S, 2S Top with Doors
BS283HW W800×D300×H1060
BS283HB W800×D300×H1060



BS283HW **BS283HB**

3S, 2S Bottom with Doors
BS283LW W800×D300×H1060
BS283LB W800×D300×H1060



BS283LW **BS283LB**

5S Open
BS085W W800×D300×H1740
BS085B W800×D300×H1740



BS085W **BS085B**

5S, 2S Mid with Doors
BS285MW W800×D300×H1740
BS285MB W800×D300×H1740



BS285MW **BS285MB**

3S, 1S Top with Doors
BS183HW W800×D300×H1060
BS183HB W800×D300×H1060



BS183HW **BS183HB**

3S, 1S Mid with Doors
BS183MW W800×D300×H1060
BS183MB W800×D300×H1060



BS183MW **BS183MB**

5S, 2S Bottom with Doors
BS385HW W800×D300×H1740
BS385HB W800×D300×H1740



BS385HW **BS385HB**

5S, 1S Mid with Doors
BS185MW W800×D300×H1740
BS185MB W800×D300×H1740



BS185MW **BS185MB**

BASIC COLOR





Easily operated controller allows height to be adjusted to fit individual body type and work type. The moving desk, which adjusts height (680 ~ 1200mm) according to customers, satisfies both sitting and standing at the same time, and improves work efficiency and user's health index.

MOVING DESK HEALTH CARE

Working on different types of people at the same desk is unhealthy for the user. Moving desk adjusts to user's body shape to create a healthy office environment and enhances work efficiency and satisfaction. A healthy office environment improves concentration and improves work efficiency, so you can work healthier and fit your body.

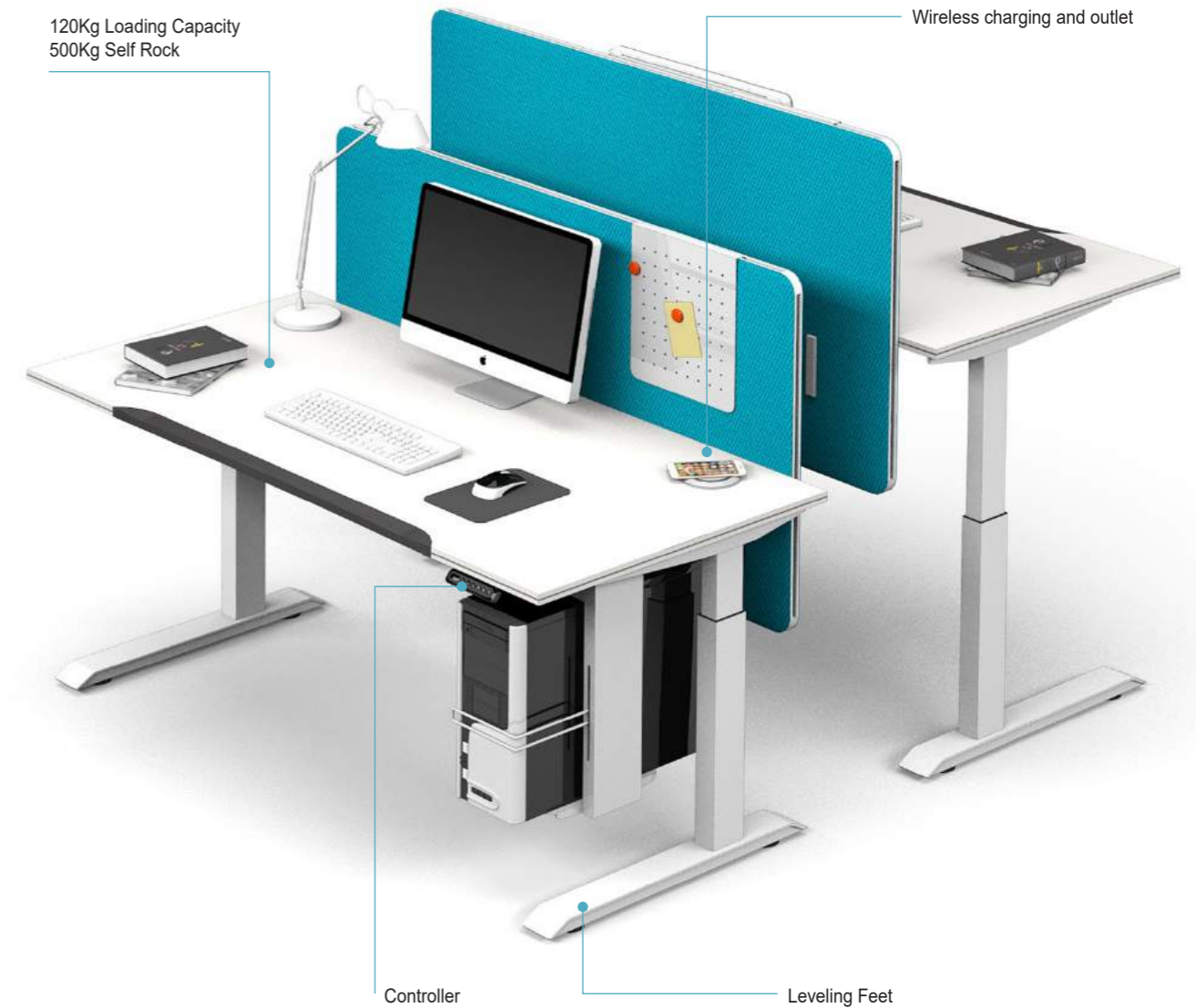

Height storage method

- 01_ After reaching the desired height, press **m** and then press **1 2 3** numbers to save.
 - 02_ You can save 3 different heights.
 - 03_ If you press the button in the specified position, the height will be adjusted automatically.
- ※ The stored height is retained even when the power is turned off.

Initial reset method

- 01_ After installing the product, check the RST mark on the "LED height display".
- 02_ Keep pressing **-** all the way down and release the button when the number appears on the "LED height display"



50dB or less motor running sound



20k self endurance tests



Standby power less than 0.1W Controller system



Rollback function in vertical operation



120Kg Loading Capacity 500Kg Self Rock

Desk, comfortable for Everyone !



TUV SUD
Completed product
performance and safety
testing by European top
authority, TUV



KC
Korea Certification
Mark (KC Mark)
HU10686-13002B



CE
National Integrated
Certification Mark CE
Acquired CE Mark of
European Standard





DETAIL

01_ Controller for easy operation
Implement the current height on the LED display.

02_ Screen
It is easy to assemble and install, and the fabric screen creates a comfortable atmosphere with eye block and sensual colors.

03_ Soft Arm Pad
It reduces the pressure on the arms and reduces fatigue on the shoulders and neck.

04_ Leveling Feet
Adjustable feet for smooth leveling on uneven surfaces



DESK

Moving Desk/ Normal Top
MSD014 W1400×D800×H680~1200
MSD016 W1600×D800×H680~1200
MSD018 W1800×D800×H680~1200



Moving Desk / Screen (15T)
MSD014S W1400×D800×H1160~1680
MSD016S W1600×D800×H1160~1680
MSD018S W1800×D800×H1160~1680



Moving Desk / Screen (30T)
MSD114S W1400×D800×H1160~1680
MSD116S W1600×D800×H1160~1680
MSD118S W1800×D800×H1160~1680



Moving Desk / PU Top
MSD014U W1400×D750×H680~1200
MSD016U W1600×D750×H680~1200
MSD018U W1800×D750×H680~1200



Moving Desk / PU Top & Screen (15T)
MSD014US W1400×D750×H1160~1680
MSD016US W1600×D750×H1160~1680
MSD018US W1800×D750×H1160~1680



Moving Desk / PU Top & Screen (30T)
MSD114US W1400×D750×H1160~1680
MSD116US W1600×D750×H1160~1680
MSD118US W1800×D750×H1160~1680



SCREEN

Screen(30T)
NWSC0012 W1200×D30×H800
NWSC0014 W1400×D30×H800
NWSC0016 W1600×D30×H800
NWSC0018 W1800×D30×H800



Screen(15T)
NWUS012 W1200×D15×H800
NWUS014 W1400×D15×H800
NWUS016 W1600×D15×H800
NWUS018 W1800×D15×H800



POWER OUTLET

Wireless charging outlet (Built-In)
NW-202MW W255×D88×H80
AC220V/60HZ



NW-221W Ø118×80
AC220V/60HZ



CABLE CHAIN

Cable Chain
NWJ-TSXG01 W90×D120×H1400

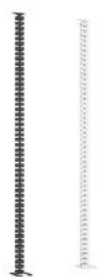

BASIC COLOR



SCREEN FABRIC

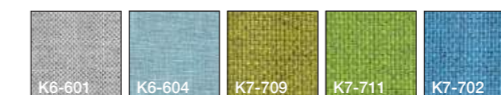







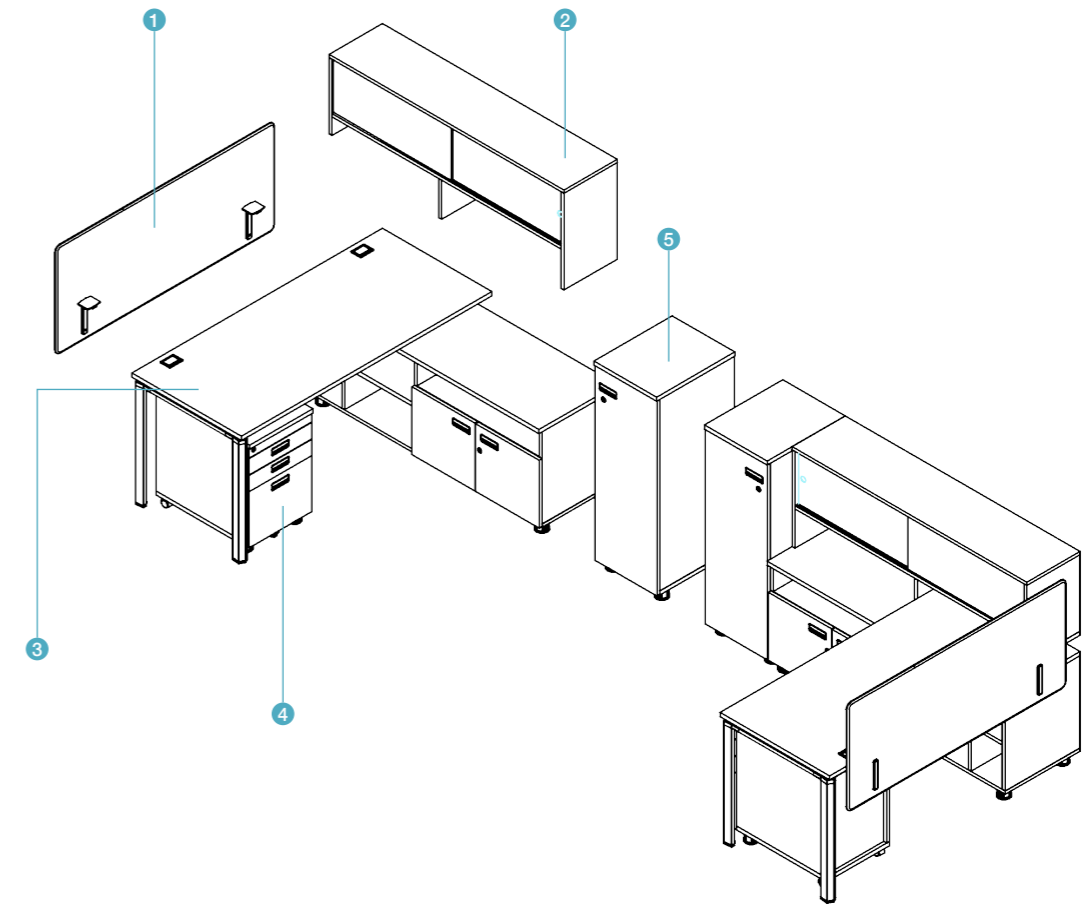

The Challenge series features combination of color and soft finish and ergonomic design that prioritize user convenience and a variety of units for a seamless layout. Reduce unnecessary area of the desk to implement an efficient use of space and a comfortable working space for the current office.

CHALLENGE series

The Challenge series is a basic design that allows you to create a workstation that's right for you, in a flexible combination with a variety of storage.



Basic structures

Image	Item	Model No.	Description
	Screen	DS0166R	The screen distinguishes the personal space with natural communication at the proper height and helps to organize the objects of the individual neatly. You can also attach a simple note using a magnet to the front memo board with the accessory on top.
	Top Storage	BS015H	Optional top storage replaces the panel to provide eye-catching, personal space and expand your storage space.
	Desk	CHD0165SD	Side cabinets combined with desks provide personal accessibility and convenient storage.
	Mobile Pedestal	DP131	Security management of personal objects is possible, and sufficient storage space is provided for efficient storage of various materials and supplies.
	Locker	LK045	Tower units, maximize personal storage, allow you to store and manage a variety of items.



Design for office



DETAIL

01_ Simple design

The modern base is simple, and the luxurious desk is not constrained by space, making it easy to relocate and move around according to the layout.

02_ Wiring Cap

Wiring cap considering safety and convenience provides enough space for vertical wiring with ABS injection cover.

03_ Inserted Handle

The metallic material and simple Inserted handle are safe to use and the unique design fits well into modern offices.

04_ Leveling Feet

The plastic injection leveler is attached to the bottom, making it easy to adjust the level even without uneven floor.



DESK

Desk

- CHD008 W800×D700×H720
- CHD010 W1000×D700×H720
- CHD012 W1200×D700×H720
- CHD014 W1400×D700×H720
- CHD016 W1600×D700×H720
- CHD018 W1800×D700×H720



Desk

- CHD014UP W1400×D700×H720
- CHD016UP W1600×D700×H720
- CHD018UP W1800×D700×H720



Desk

- CHD0164SD W1600×D1500×H720
- CHD0184SD W1800×D1500×H720

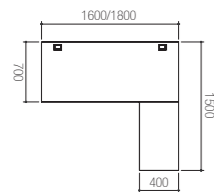

Desk

- CHD0165SD W1600×D1500×H720
- CHD0185SD W1800×D1500×H720

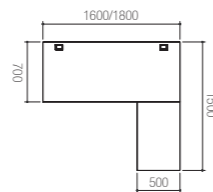

Desk

- CHD014UPS W1400×D700×H720
- CHD016UPS W1600×D700×H720



Desk

- CHD0165SDD W1600×D1500×H720
- CHD0185SDD W1800×D1500×H720



BASIC COLOR

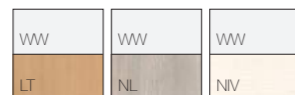

DRAWER

Mobile Pedestal

- DP130 W403×D580×H605

※ Injection internal drawer



Mobile Pedestal

- DP230DW W403×D550×H603

※ Wood internal drawers



Mobile Pedestal

- DP131 W403×D580×H605

※ Internal injection drawer (bottom file)



SIDE CABINET

Side Cabinet

- SD075 W700×D500×H720
- SD085 W800×D500×H720

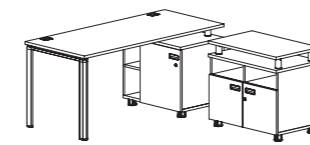

SD085 + CHD016UP

Side Cabinet

- BS082SD W800×D400×H607

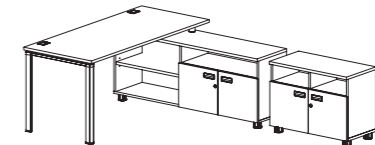

BS082SD + CHD0164SD

Side Cabinet

- SDCW853 W800×D500×H720



In door lock

BASIC COLOR

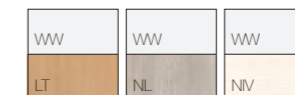



SCREEN

Screen

- DS0086R** W800×D15×D800
- DS0106R** W1000×D15×D800
- DS0126R** W1200×D15×H800
- DS0146R** W1400×D15×H800
- DS0166R** W1600×D15×H800
- DS0186R** W1800×D15×H800

※ Rounded Wooden Screen



Screen(30T)

- NWSC0012** W1200×D30×H800
- NWSC0014** W1400×D30×H800
- NWSC0016** W1600×D30×H800
- NWSC0018** W1800×D30×H800



Screen(15T)

- NWUS012** W1200×D15×H800
- NWUS014** W1400×D15×H800
- NWUS016** W1600×D15×H800
- NWUS018** W1800×D15×H800



TOP STORAGE

Top Storage

BS015H W1500×D360×H553

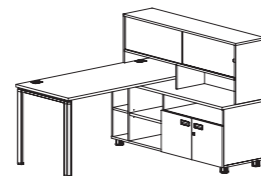

BS015H + CHD0165SD

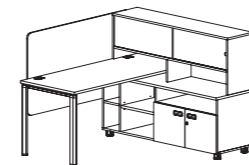

BS015H + CHD0165SD + DS0146R

Top Storage

BS007NMH W700×D300×H440

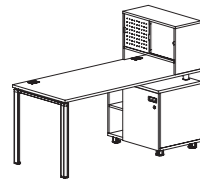

BS007NMH + CHD016UP



Top Storage

BS007H W700×D300×H440

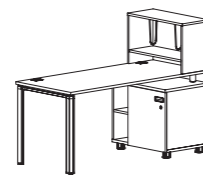

BS007H + CHD016UP



MEMO BOARD

Memo Board

DS030A W300×D19×H350



※ Hanging Over Wood Screen
(Magnetic Use)

Memo Board

DS0618A W600×D19×H100



※ Hanging Over Wood Screen
(Magnetic Use)

BASIC COLOR



BASIC COLOR



SCREEN FABRIC





※ When placing a single wardrobe next to a desk, make sure that it is fixed with a fixed hardware.(Risk of Falling)



Locker for 1 (Regular type)



Locker for 1 with Shelves



Locker for 1 with Drawer

LOCKER

Locker
LK1237 W200×D700×H1160



Locker
LK045 W400×D500×H1160



Locker
LK1237B W200×D700×H1160



Locker
LK1437B W400×D700×H1160



Locker
LK2437 W400×D700×H1160



Locker
LK1437P W400×D700×H1160



Locker
LK2437B W400×D700×H1160



In door lock

BASIC COLOR

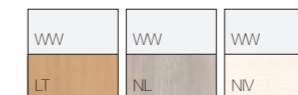

CHALLENGE series

With an open structure and design that supports smooth communication, flexible space partitioning, and various items that can be freely applied as needed differentiated solutions complete the special competitiveness of the Smart Office era.



No.	Model No.	Dimension	Qty	
1	Desk	CHD0165SDD	W1600×D1500×H720	4
2	Locker	LK045	W400×D500×H1160	4
3	Top Storage	BS015H	W1500×D360×H553	4
4	Screen	NWSC0014	W1400×D30×H800	4
Total			16	



No.	Model No.	Dimension	Qty	
1	Desk	CHD016UP	W1600×D700×H720	3
2	Side Cabinet	SDCW853	W800×D500×H720	3
3	Screen	NWSC0014	W1400×D30×H800	3
Total			9	



No.	Model No.	Dimension	Qty	
1	Desk	CHD014	W1400×D700×H720	2
2	Mobile Pedestal	DP130	W403×D580×H605	2
3	Locker	LK2437	W400×D700×H1160	1
4	Screen	NWSC0014	W1400×D30×H800	2
Total			7	



No.	Model No.	Dimension	Qty	
1	Desk	CHD0165SDD	W1600×D1500×H720	2
2	Locker	LK045	W400×D500×H1160	2
3	Top Storage	BS015H	W1500×D360×H553	2
4	Screen	NWSC0014	W1400×D30×H800	2
Total			8	





Desk+Side Cabinet
 +Locker+Screen+Task
 Chair



Desk+Side Cabinet+Top
 Storage+Locker+Screen+Task
 Chair



Desk+Side Cabinet
 +Bookshelf+Locker+Screen
 +Task Chair



Desk+Side Cabinet+Top
 Storage+Locker+Screen+Task
 Chair



No.	Model No.	Dimension	Qty	
1	Desk	CHD0165SDD	W1600×D1500×H720	2
2	Locker	LK045	W400×D500×H1160	2
3	Top Storage	BS015H	W1500×D360×H553	2
4	Screen	NWSC0014	W1400×D30×H800	1
Total			7	



No.	Model No.	Dimension	Qty	
1	Desk	CHD0165SDD	W1600×D1500×H720	2
2	Locker	LK045	W400×D500×H1160	2
3	Top Storage	BS015H	W1500×D360×H553	2
4	Screen	NWSC0014	W1400×D30×H800	1
Total			7	



No.	Model No.	Dimension	Qty	
1	Desk	CHD0165SDD	W1600×D1500×H720	2
2	Locker	LK045	W400×D500×H1160	2
3	Top Storage	BS015H	W1500×D360×H553	2
4	Screen	NWSC0014	W1400×D30×H800	1
Total			7	



No.	Model No.	Dimension	Qty	
1	Desk	CHD0165SDD	W1600×D1500×H720	2
2	Locker	LK045	W400×D500×H1160	2
3	Top Storage	BS015H	W1500×D360×H553	2
4	Screen	NWSC0014	W1400×D30×H800	2
Total			8	



No.	Model No.	Dimension	Qty	
1	Desk	CHD0165SDD	W1600×D1500×H720	2
2	Locker	LK045	W400×D500×H1160	2
3	Top Storage	BS015H	W1500×D360×H553	2
4	Screen	NWSC0014	W1400×D30×H800	1
Total			7	

OFFICE FURNITURE
SQUARE series

Square Series

OFFICE

The basic design makes it possible to place layouts in office spaces and at home. The stylish square series with various color configurations makes it easy to produce workstation space.



Design for office



DETAIL

01_ Simple design

The modern base has a simple yet luxurious desk that is not restricted by space, making it easy to relocate and move around.

02_ Wiring Cap

Top cable cap considering safety and convenience provides enough space for vertical wiring with ABS injection cover.

03_ Inserted Handle

The metallic material and simple inserted handle are safe to use and the unique design fits well into modern offices.

04_ Leveling Feet

The plastic injection leveler is attached to the bottom, making it easy to adjust the level even without uneven floor.

05_ Memo board

Magnets can be attached so you can attach notes or photos.

DESK

Desk
SQD008 W800×D700×H720
SQD010 W1000×D700×H720
SQD012 W1200×D700×H720
SQD014 W1400×D700×H720
SQD016 W1600×D700×H720
SQD018 W1800×D700×H720



Desk
SQDBS012 W1200×D700×H1020
SQDBS014 W1400×D700×H1020
SQDBS016 W1600×D700×H1020



DRAWER

Mobile Pedestal
DP020 W403×D580×H500



Mobile Pedestal
DP021P W403×D580×H550



Mobile Pedestal
CB011 W403×D580×H550



SCREEN

Screen
DS0086 W800×D15×H600
DS0106 W1000×D15×H600
DS0126 W1200×D15×H600
DS0146 W1400×D15×H600
DS0166 W1600×D15×H600
DS0186 W1800×D15×H600



MEMO BOARD

Memo Board
DS030A W300×D19×H350



Memo Board
DS0618A W600×D19×H100



BASIC COLOR



LOCKER

Locker
LK1237 W200×D700×H1160



Locker
LK045 W400×D500×H1160



Locker
LK1237B W200×D700×H1160



Locker
LK1437B W400×D700×H1160



Locker
LK2437 W400×D700×H1160



Locker
LK1437 W400 D700 H1160



Locker
LK1437P W400×D700×H1160



Locker
LK2437B W400×D700×H1160



SIDE CABINET

Bookshelf
BS0122 W1200×D400×H500



Bookshelf
BS0122P W1200×D400×H550



TOP STORAGE

Top Storage
BS007NMH W700×D300×H440



Top Storage
BS007H W700×D300×H440



BASIC COLOR





No.	Model No.	Dimension	Qty	
1	Desk	SQD014	W1400×D700×H720	4
2	Locker	LK2437	W400×D700×H1160	2
3	Mobile Pedestal	DP020	W403×D580×H500	4
4	Partition	MF2B-11608	W800×D45×H1160	12
5	Post	MF2P-1160	W45×D45×H1160	4
6	End bar	MF2EC-1160	W45×D10×H1160	4
Total			30	



No.	Model No.	Dimension	Qty	
1	Desk	SQD014	W1400×D700×H720	3
2	Locker	LK1237	W200×D700×H1160	3
3	Screen	DS0146	W1400×D15×H600	3
4	Desk	BS0122P	W1200×D400×H550	3
5	Memo Board	DS030A	W300×D19×H350	3
Total			15	



No.	Model No.	Dimension	Qty	
1	Desk	SQD016	W1600×D700×H720	6
2	Top Storage	BS007NMH	W700×D300×H440	6
3	Mobile Pedestal	DP020	W403×D580×H500	2
4	Mobile Pedestal	CB011	W403×D580×H550	2
5	Mobile Pedestal	DP021P	W403×D580×H550	2
Total			18	



No.	Model No.	Dimension	Qty	
1	Desk	SQD014	W1400×D700×H720	2
2	Locker	LK2437	W400×D700×H1160	1
3	Mobile Pedestal	DP021P	W403×D580×H550	1
4	Bookshelf	BS0122P	W1200×D400×H550	1
5	Screen	DS0146	W1400×D15×H600	2
Total			7	



OFFICE FURNITURE
SOLOMON series



Solomon, which is designed to be used in various work environments through the combination of various units, is a product that shows the wisdom to configure each new unit according to the situation. Create a more effective office environment with Solomon's wisdom.

OFFICE FURNITURE
SOLOMON series

Solomon Series

Solomon is a product that is optimized for the combination of various units. The screens and partitions all blend together as if they were set previously, and the simple feel can stimulate the customer's aesthetics.

OFFICE



PANEL



SCREEN FABRIC

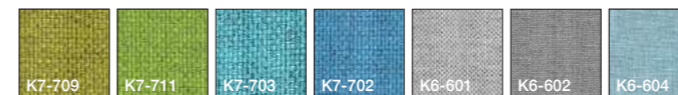



DESK

Desk
SMD142 W1400×D1200×H720
SMD162 W1600×D1200×H720



Desk
SMD012 W1200×D700×H720
SMD014 W1400×D700×H720
SMD016 W1600×D700×H720



DRAWER

Mobile Pedestal
DP130 W403×D580×H605

※ Injection internal drawer



Mobile Pedestal
DP230DW W403×D550×H603

※ Wood internal drawers



Mobile Pedestal
DP131 W403×D580×H605

※ Internal injection drawer (bottom file)



BASIC COLOR

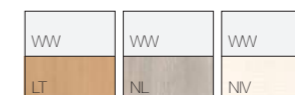

SIDE CABINET

Side Cabinet
SMBS065 W600×D550×H720
SMBS067 W600×D700×H720



SMBS065+SMD162

SMBS067+SMD162

Side Cabinet
SMBS167 W600×D700×H1160
SMBS187 W800×D700×H1160



SMBS167/SMBS187+SMD162

Side Cabinet
SMBS265 W600×D550×H1160
SMBS267 W600×D700×H1160



SMBS265+SMD162

SMBS267+SMD162



CABINET

Cabinet
SMCB065 W600×D550×H720
SMCB067 W600×D700×H720



SMCB065+SMD162

SMCB067+SMD162

Cabinet
SMCB167 W600×D700×H1160
SMCB187 W800×D700×H1160



SMCB167/SMCB187+SMD162

Cabinet
SMCB265 W600×D550×H1160
SMCB267 W600×D700×H1160



SMCB265+SMD162

SMCB267+SMD162

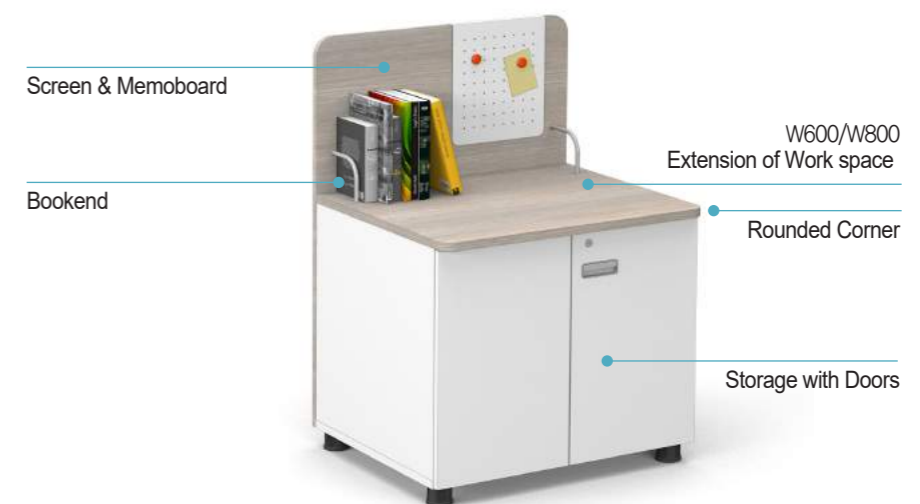

BASIC COLOR



BASIC COLOR



CABINET

Cabinet(Drawer&PC Holder)
SMDP065 W600×D550×H720
SMDP067 W600×D700×H720



SMDP065+SMD162

SMDP067+SMD162

Cabinet(Drawer&PC Holder)
SMDP167 W600×D700×H1160



SMDP167+SMD162

Cabinet(Drawer&PC Holder)
SMDP265 W600×D550×H1160
SMDP267 W600×D700×H1160



SMDP265+SMD162

SMDP267+SMD162

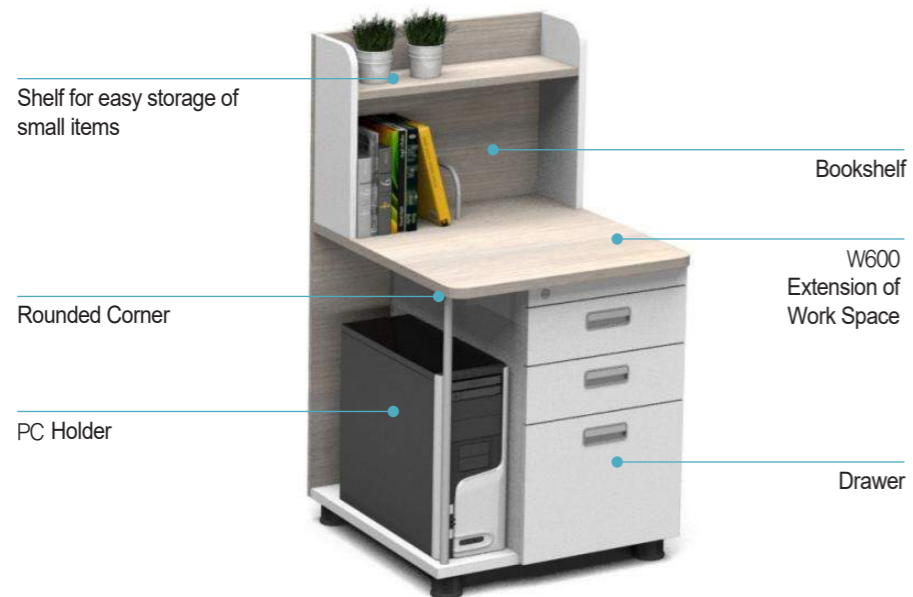

LOCKER

Locker with PC holder
SMLK154 W400×D550×H1160
SMLK174 W400×D700×H1160



SMLK174+SMD162

SMLK154+SMD162

Locker with PC holder
SMLK156 W600×D550×H1160
SMLK176 W600×D700×H1160



SMLK176+SMD162

SMLK156+SMD162

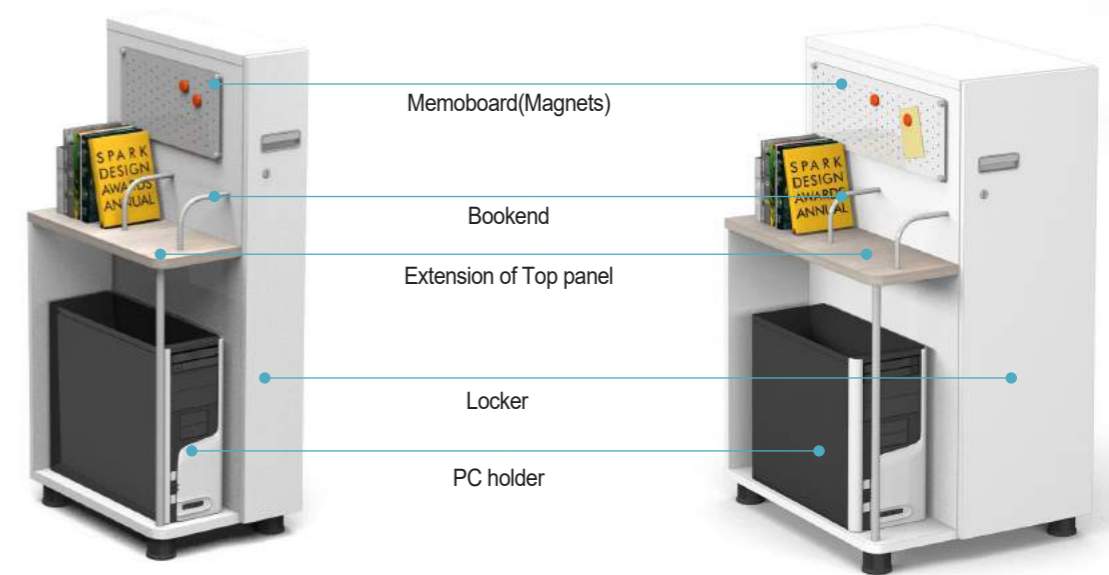

BASIC COLOR



BASIC COLOR



OFFICE FURNITURE
SOLOMON series

Solomon, which is designed to be used in various work environments through the combination of various units, is a product that shows the wisdom to configure each new unit according to the situation. Create a more effective office environment with Solomon's wisdom.

You can increase work efficiency with the expandability and convenience of the work space due to the combination of units.



CABINET

Bookshelf (2S Open)
BS182 W800×D405×H816



Bookshelf (3S Open)
BS183 W800×D405×H1167



Bookshelf (4S Open)
BS184 W800×D380×H1530



Bookshelf (5S Open)
BS185 W800×D380×H1893



Bookshelf (6S Open)
BS186 W800×D380×H2256



CABINET

Bookshelf (3S Half Doors)
BS183DL W800×D405×H1167



Bookshelf (4S Half Doors)
BS184DL W800×D405×H1530



Bookshelf (5S Half Doors)
BS185DL W800×D400×H1893



Bookshelf (5S Half Glass Doors)
BS185GH W800×D400×H1893



Bookshelf (6S Half Doors)
BS186DL W800×D400×H2256



Bookshelf (5S Half Glass Doors)
BS186GH W800×D400×H2256



- 1800 Visual Block(Wall)
- 1500 Individual privacy protection
- 1200 Cpmunication



BASIC COLOR

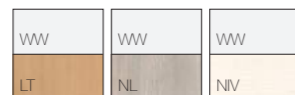

BASIC COLOR

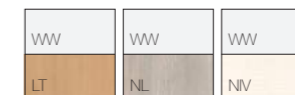

CABINET

2S Cabinet
CB182 W800×D405×H816



3S Cabinet
CB183 W800×D405×H1167



4S Cabinet
CB184 W800×D405×H1530



5S Cabinet
CB185 W800×D400×H1893



5S Cabinet (4 Doors)
CB185D4 W800×D400×H1893



6S Cabinet
CB186 W800×D400×H2256



6S Cabinet (4 Doors)
CB186D4 W800×D400×H2256



CABINET

5S Narrow Cabinet
CB155 W500×D400×H1893



LOCKER

Locker for 1
LK1554 W500×D400×H1893



BASIC COLOR

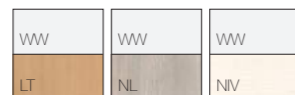

BASIC COLOR

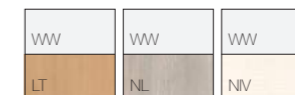



No.	Model No.	Dimension	Qty	
1	Desk	SMD014	W1400×D700×H720	4
2	Locker & PC Holder	SMLK176	W600×D700×H1160	4
3	Mobile Pedestal	DP131	W403×D580×H605	4
4	Partition	PSC0082	W800×D32×H1200	4
5	Partition	PSC102	W1000×D32×H1200	8
6	Post	PSC6002	W26.5×D26.5×H1065	4
Total			28	

No.	Model No.	Dimension	Qty	
1	Desk	SMD014	W1400×D700×H720	4
2	Locker & PC Holder	SMLK176	W600×D700×H1160	4
3	Mobile Pedestal	DP131	W403×D580×H605	4
4	Side Cabinet	SMCB187	W800×D700×H1160	2
5	Partition	MF2B-11608	W800×D45×H1160	6
6	Partition	MF2B-116010	W1000×D45×H1160	8
7	Post	MF2P-1160	W45×D45×H1160	4
8	End bar	MF2EC-1160	W45×D10×H1160	4
Total			36	



No.	Model No.	Dimension	Qty	
1	Desk	SMD014	W1400×D700×H720	4
2	Locker & PC Holder	SMLK176	W600×D700×H1160	4
3	Mobile Pedestal	DP131	W403×D580×H605	4
4	Partition	MF2B-11608	W800×D45×H1160	4
5	Partition	MF2B-116010	W1000×D45×H1160	8
6	Post	MF2P-1160	W45×D45×H1160	4
7	End bar	MF2EC-1160	W45×D10×H1160	4
Total			32	



No.	Model No.	Dimension	Qty	
1	Desk	SMD162	W1600×D1200×H720	4
2	Locker & PC Holder	SMLK156	W600×D550×H1160	4
3	Mobile Pedestal	DP131	W403×D580×H605	4
4	Partition	MF2B-11606	W600×D45×H1160	4
5	Partition	MF2B-11608	W800×D45×H1160	8
6	Partition	MF2B-116012	W1200×D45×H1160	4
7	Post	MF2P-1160	W45×D45×H1160	4
8	End bar	MF2EC-1160	W45×D10×H1160	4
Total			36	

OFFICE FURNITURE
VIBE DESK series

Vibe Desk Series



The vibe desk series has a smooth curve and an ergonomic wave design that enhances work efficiency. Complete your creative tasks with the Vibe Desk series.

VIBE DESK series

The vibe desk series has a smooth curve and an ergonomic wave design that enhances work efficiency. Complete your creative tasks with the Vibe Desk series..



VIBE DESK series

The vibe desk series has a smooth curve and an ergonomic wave design that enhances work efficiency. Complete your creative tasks with the Vibe Desk series.



Design for office

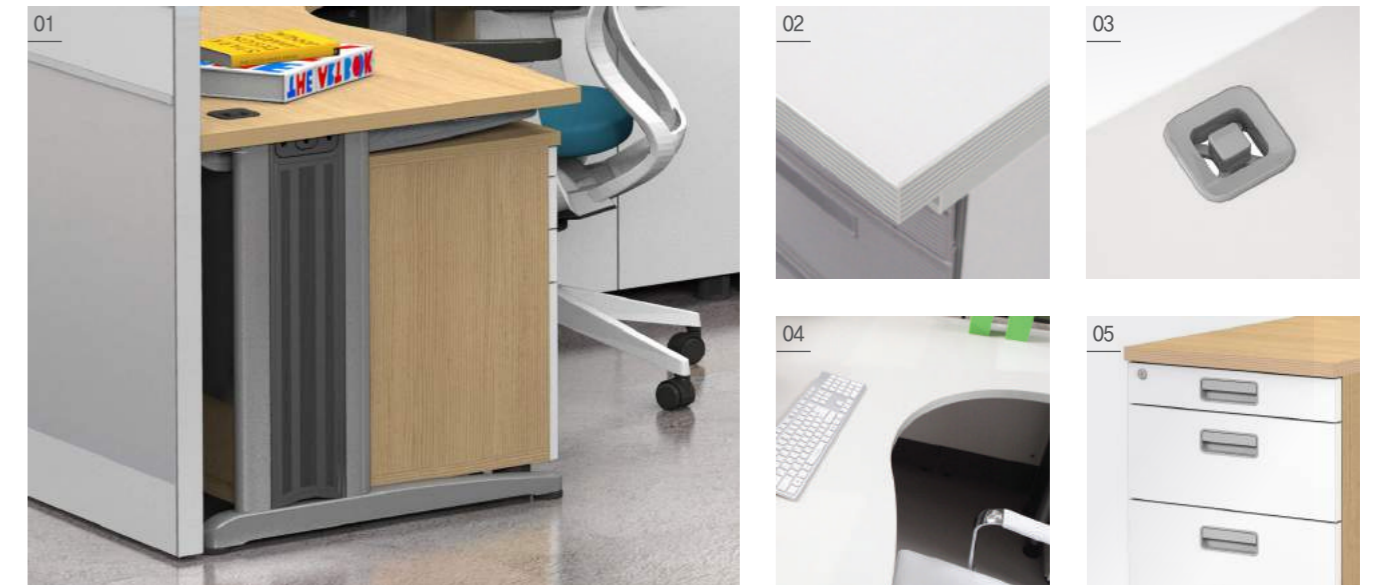

DETAIL

01_ Vertical / horizontal wiring

Sufficient space for vertical wiring is secured on the side of the leg, which is closed by a removable injection cover, and wires raised from the floor are connected to the OA through hole caps.

02_ Multi Edge

Simple multi-edges make your office space come alive.

03_ Wiring Cap

Top cable cap considering safety and convenience provides enough space for vertical wiring with ABS injection cover.

04_ Round tops

The simple wave top design not only looks beautiful but also considers the user's movement.

05_ Inserted Handle

The metallic material and simple inserted handle are safe to use and the unique design fits well into modern offices.

VIBE DESK series

The vibe desk series has a smooth curve and an ergonomic wave design that enhances work efficiency. Complete your creative tasks with the Vibe Desk series.



DESK

- Desk
PD010 W1000×D720×H720
PD012 W1200×D720×H720
PD014 W1400×D720×H720
PD016 W1600×D720×H720



- Desk
PD114L/R W1400×D1200×H720
PD116L/R W1600×D1200×H720
PD118L/R W1800×D1200×H720

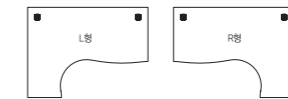

- Side Desk(U Shape)
SD012U W1200×D600×H720



DRAWER

- Mobile Pedestal
DP130 W403×D580×H605

※ Injection internal drawer



- Mobile Pedestal
DP230DW W403×D550×H603

※ Wood internal drawers



- Mobile Pedestal
DP131 W403×D580×H605

※ Internal injection drawer (bottom file)



BASIC COLOR

LT	UA	MB	LG
MG	MG	MG	MG

OFFICE FURNITURE
VIBE DESK series

SIDE CABINET

Side Cabinet
CB062SDF W600 D450 H720

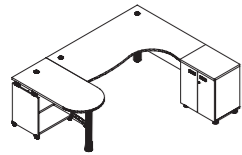

CB062SDF + SD012U + PD114L/R

Side Cabinet
CB062SD W600x D720x H720

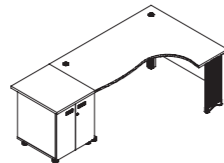

CB062SD + PD114L/R

Side Cabinet
BS0820SD W800x D450x H720



Side Filing Cabinet
FC245 W404x D450x H720



Side Filing Drawer
FC272 W404x D720x H720



FILING CABINET

Filing Cabinet
FC142 W404x D580x H743



Filing Cabinet
FC143 W404x D580x H1047



Filing Cabinet
FC144 W404x D580x H1350



BASIC COLOR

LT	UA	MB	LG
MG	MG	MG	MG



VIBE DESK series

The combination of color, smooth finish, and ergonomic design of the Vibe Series give the user a high level of comfort, and the combination of various units makes the layout suitable for the application. It reduces unnecessary desk space and provides efficient space utilization and comfortable work space for the office.



No.	Model No.	Dimension	Qty	
1	Desk	PD116L/R	W1600×D1200×H720	4
2	Mobile Pedestal	DP131	W403×D580×H605	4
3	Side Cabinet	CB062SDF	W600×D450×H720	4
4	U Side Cabinet	SD012U	W1200×D600×H720	2
5	Conference Table	RCT290	Ø900×H720	1
6	Partition	MF2B-11606	W600×D45×H1160	6
7	Partition	MF2B-11608	W800×D45×H1160	8
8	Partition	MF2B-116012	W1200×D45×H1160	4
9	Post	MF2P-1160	W45×D45×H1160	4
10	End bar	MF2EC-1160	W45×D10×H1160	4
Total			41	



No.	Model No.	Dimension	Qty	
1	Desk	PD116L/R	W1600×D1200×H720	2
2	Mobile Pedestal	DP131	W403×D580×H605	2
3	Side Cabinet	CB062SDF	W600×D450×H720	2
4	U Side Desk	SD012U	W1200×D600×H720	1
5	Conference Table	RCT290	Ø900×H720	1
6	Partition	MF2B-11606	W600×D45×H1160	3
7	Partition	MF2B-11608	W800×D45×H1160	4
8	Partition	MF2B-116012	W1200×D45×H1160	2
9	Post	MF2P-1160	W45×D45×H1160	2
10	End bar	MF2EC-1160	W45×D10×H1160	2
Total			21	



No.	Model No.	Dimension	Qty	
1	Desk	PD014	W1400×D720×H720	6
2	Mobile Pedestal	DP131	W403×D580×H605	6
3	Partition	MF2B-11607	W700×D45×H1160	10
4	Post	MF2P-1160	W45×D45×H1160	2
5	End bar	MF2EC-1160	W45×D10×H1160	4
Total			28	



No.	Model No.	Dimension	Qty	
1	Desk	PD116L/R	W1600×D1200×H720	1
2	Mobile Pedestal	DP131	W403×D580×H605	1
3	Side Cabinet	CB062SDF	W600×D450×H720	1
4	U Side Desk	SD012U	W1200×D600×H720	1
5	Conference Table	RCT290	Ø900×H720	1
6	Partition	MF2B-11606	W600×D45×H1160	1
7	Partition	MF2B-11608	W800×D45×H1160	3
8	Partition	MF2B-116012	W1200×D45×H1160	3
9	Post	MF2P-1160	W45×D45×H1160	2
10	End bar	MF2EC-1160	W45×D10×H1160	2
Total			16	

OFFICE FURNITURE
BASIC DESK series

Basic Desk Series



Clean, modern design and integrated base leveling leg, increase the durability of the Basic desk, wiring capabilities of a simple perforated steel plate is effective for layout changes.

BASIC DESK series

Basic Desk series forms a flexible combination of various storage as a basic design allows you to configure a workstation to fit the user.



Design for office

**DETAIL****01_ Vertical Wire Duct**

The wiring duct finished on the side of the desk can be used as a vertical wiring space for wires coming from the office floor.

02_ Screen

It prevents falling office equipment on the desk, protects privacy, and attaches a memo board.

03_ Wiring hole

Top wiring cap considering safety and convenience provides enough space for vertical wiring with ABS injection cover.

04_ Functional handle

The simple yet functional handle is designed to prevent accidents.

05_ Leveling Feet

Rotating feet can be used for stable leveling.



DESK

Desk

- SD012** W1200×D760×H720
- SD014** W1400×D760×H720
- SD016** W1600×D760×H720
- SD018** W1800×D760×H720

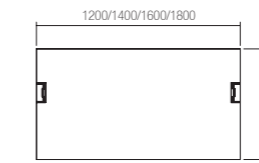

Side Desk (U Shape)

- SD112S** W1200×D600×H720

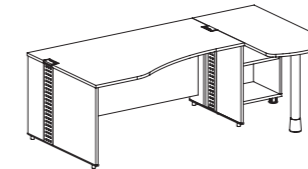

SD112S + SD114L/R

SIDE CABINET

Side Cabinet

- CB062DS** W600×D405×H720
- CB082DS** W800×D405×H720

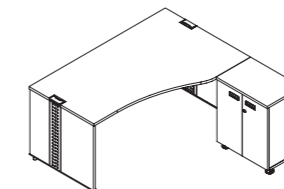

CB062DS + SD114L/R

Desk

- SD114L/R** W1400×D1000×H720
- SD116L/R** W1600×D1000×H720
- SD118L/R** W1800×D1000×H720

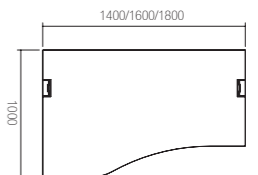

Side Bookshelf

- BS062DS** W600×D400×H720
- BS082DS** W800×D400×H720

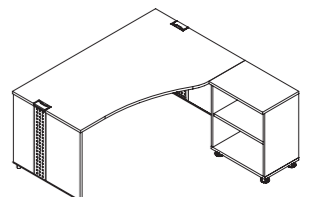

BS062DS + SD114L/R

BASIC COLOR



SCREEN

Screen

- DS0086 W800×D15×H600
- DS0106 W1000×D15×H600
- DS0126 W1200×D15×H600
- DS0146 W1400×D15×H600
- DS0166 W1600×D15×H600
- DS0186 W1800×D15×H600



MEMO BOARD

Memo Board

- DS030A W300×D19×H350



Memo Board

- DS0618A W600×D19×H100



DRAWER

Mobile Pedestal

- DP130 W403×D580×H605

※ Injection internal drawer



Mobile Pedestal

- DP230DW W403×D550×H603

※ Wood internal drawers



Mobile Pedestal

- DP131 W403×D580×H605

※ Internal injection drawer (bottom file)



FILING CABINET

Filing Cabinet

- FC142 W404×D580×H743



Filing Cabinet

- FC143 W404×D580×H1047



Filing Cabinet

- FC144 W404×D580×H1350



BASIC COLOR

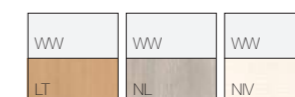



No.	Model No.	Dimension	Qty	
1	Desk	SD116L/R	W1600×D1000×H720	4
2	Side Cabinet	CB062DS	W600×D405×H720	4
3	U Side desk	SD112S	W1200×D600×H720	2
4	Screen	DS0166	W1600×D15×H600	2
5	Mobile Pedestal	DP230DW	W403×D550×H603	4
Total			16	



No.	Model No.	Dimension	Qty	
1	Desk	SD116L/R	W1600×D1000×H720	2
2	U Side Desk	SD112S	W1200×D600×H720	1
3	Screen	DS0166	W1600×D15×H600	2
4	Mobile Pedestal	DP230DW	W403×D550×H603	2
Total			7	



No.	Model No.	Dimension	Qty	
1	Desk	SD014	W1400×D760×H720	4
2	Desk	SD116L/R	W1600×D1000×H720	1
3	Side Cabinet	CB062DS	W600×D405×H720	1
4	U Side Desk	SD112S	W1200×D600×H720	3
5	Screen	DS0166	W1600×D15×H600	1
6	Screen	DS0146	W1400×D15×H600	2
7	Mobile Pedestal	DP230DW	W403×D550×H603	5
Total			17	



No.	Model No.	Dimension	Qty	
1	Desk	SD116L/R	W1600×D1000×H720	1
2	Side Cabinet	CB062DS	W600×D405×H720	1
3	U Side Desk	SD112S	W1200×D600×H720	1
4	Screen	DS0166	W1600×D15×H600	1
5	Mobile Pedestal	DP230DW	W403×D550×H603	1
Total			5	





Top Desk II features a combination of simple design and sophisticated color. Top and side panels use brackets to induce airflow



Design for office



DETAIL

01_ Wiring Cap

Top wiring cap considering safety and convenience provides enough space for vertical wiring with ABS injection cover.

02_ Bracket

By applying a bracket with a stylish image, it provides space between the top and side plates of the product to help free wiring.

03_ Handle

Metallic materials and simple handles are safe to use and the unique design fits well into modern offices.

04_ Leveling Feet

Plastic injection leveling feet are attached to the bottom for easy leveling.



DESK

Desk

- TD012** W1200×D800×H720
- TD016** W1600×D800×H720
- TD018** W1800×D800×H720



Desk

- TD018M** W1800×D800×H720



Desk

- STD012** W1200×D700×H720
- STD014** W1400×D700×H720
- STD016** W1600×D700×H720



Side Desk

- TD012DS** W1200×D420×H670



Side Desk

- STD112DS** W1200×D500×H720



DRAWER

Mobile Pedestal

- DP230DW** W403×D550×H603

※ Wood internal drawers



BASIC COLOR

LT	UA	MB	LG
SW	SW	SW	SW



No.	Model No.	Dimension	Qty	
1	Desk	STD014	W1400×D700×H720	3
2	Mobile Pedestal	DP230DW	W403×D550×H603	3
3	Partition	MF2B-11607	W700×D45×H1160	6
4	Partition	MF2B-116010	W1000×D45×H1160	2
5	Post	MF2P-1160	W45×D45×H1160	2
6	End bar	MF2EC-1160	W45×D10×H1160	2
Total			18	



No.	Model No.	Dimension	Qty	
1	Desk	STD016	W1600×D700×H720	1
2	Mobile Pedestal	DP230DW	W403×D550×H603	1
3	Side Desk	STDS112	W1200×D500×H720	1
Total			%	



No.	Model No.	Dimension	Qty	
1	Desk	STD014	W1400×D700×H720	6
2	Mobile Pedestal	DP230DW	W403×D550×H603	6
3	Partition	MF2B-11607	W700×D45×H1160	6
4	Partition	MF2B-116010	W1000×D45×H1160	4
5	Post	MF2P-1160	W45×D45×H1160	2
6	End bar	MF2EC-1160	W45×D10×H1160	4
Total			28	



No.	Model No.	Dimension	Qty	
1	Desk	STD014	W1400×D700×H720	4
2	Desk	STD016	W1600×D700×H720	1
3	Side Desk	STDS112	W1200×D500×H720	1
4	Mobile Pedestal	DP230DW	W403×D550×H603	5
5	Partition	MF2B-11607	W700×D45×H1160	4
6	Partition	MF2B-116010	W1000×D45×H1160	4
7	Post	MF2P-1160	W45×D45×H1160	2
8	End bar	MF2EC-1160	W45×D10×H1160	4
Total			25	

Dividing the storage space, applying the simple handle, stylish design and color, and satisfying the function of expansion of the storage space, it is made more robust and improved durability.



DETAIL

01_ Inserted handle

The simple inserted handle in metallic material is safe to use and its unique design fits well into modern offices.

02_ Leveling Feet

A plastic injection leveling foot can be attached to the bottom for easy leveling.

03_ Door damping hinge

A damping hinge prevents shock noises when the door is closed.



CABINET

2S Cabinet (Door)
CB082 W800×D405×H810



2S Bookshelf (Open)
BS082 W800×D405×H810



CABINET

3S Bookshelf (Half Door)
BS083DL W800×D405×H1160



3S Bookshelf (Open)
BS083 W800×D405×H1160



3S Cabinet (Door)
CB083 W800×D405×H1160



3S Cabinet (Double Door)
CB083DD W800×D500×H1160



CABINET

4S Cabinet (Door)
CB084 W800×D405×H1500



4S Bookshelf (Open)
BS084 W800×D405×H1500



4S Bookshelf (Half Door)
BS084DL W800×D405×H1500



BASIC COLOR



CABINET

3S Cabinet (Upper)
CB083H W800×D400×H1070



Stack on Cabinet
CB081H W800×D400×H400



3S Cabinet (Lower)
CB083L W800×D400×H1130



CABINET

5S Cabinet (Narrow Door)
CB055 W500×D400×H1880



LOCKER

Locker
LK0554 W500×D400×H1880



BASIC COLOR



CABINET

5S Cabinet (Door)
CB085 W800×D400×H1880



5S Cabinet (4 Door)
CB085D4 W800×D400×H1880



5S Cabinet (Double Door)
CB085DD W800×D500×H1880



5S Bookshelf (Open)
BS085 W800×D380×H1880



5S Bookshelf (Half Door)
BS085DL W800×D400×H1880



5S Bookshelf (Half Glass Door)
BS085GH W800×D400×H1880



5S Bookshelf (Glass Door)
BS085G W800×D400×H1880



BASIC COLOR

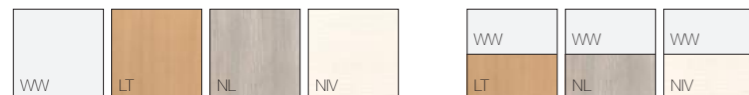

CABINET

6S Cabinet (Narrow Door)
CB056 W500×D400×H2200



6S Cabinet (Door)
CB086 W800×D400×H2200



6S Bookshelf (Open)
BS086 W800×D380×H2200



6S Bookshelf (Half Glass Door)
BS086GH W800×D400×H2200



BASIC COLOR



LOCKER

Locker
LK0564 W500×D400×H2200



6S Cabinet (4 Door)
CB086D4 W800×D400×H2200



6S Bookshelf (Half Door)
BS086DL W800×D400×H2200



6S Bookshelf (4 Glass Door)
BS086G4 W800×D400×H2200





DETAIL

01_ Inserted handle
The simple inserted handle in metallic material is safe to use and its unique design fits well into modern offices.

02_ Leveling Feet
A plastic injection leveling foot can be attached to the bottom for easy leveling.

KEY SYSTEM



LOCKER

Locker for 1
LK0356 W300×D570×H1880
LK0456 W400×D570×H1880
LK0556 W500×D570×H1880



Locker for 2
LK1356 W300×D570×H1880
LK1456 W400×D570×H1880
LK1556 W500×D570×H1880



Locker for 2
LK2656 W600×D570×H1880
LK2856 W800×D570×H1880



Locker for 4
LK4656 W600×D570×H1880
LK4856 W800×D570×H1880



Locker for 3
LK3956 W900×D570×H1880



Locker for 6
LK6956 W900×D570×H1880



BASIC COLOR



LOCKER Dial Key

Locker for 1
LK0356DK W300×D570×H1880
LK0456DK W400×D570×H1880
LK0556DK W500×D570×H1880



Locker for 2
LK1356DK W300×D570×H1880
LK1456DK W400×D570×H1880



Locker for 2
LK2656DK W600×D570×H1880
LK2856DK W800×D570×H1880



Locker for 4
LK4656DK W600×D570×H1880
LK4856DK W800×D570×H1880



Locker for 3
LK3956DK W900 D570 H1880



Locker for 6
LK6956DK W900 D570 H1880



LOCKER Electronic Key

Locker for 1
LK0356EK W300×D570×H1880
LK0456EK W400×D570×H1880
LK0556EK W500×D570×H1880



Locker for 2
LK1356EK W300×D570×H1880
LK1456EK W400×D570×H1880



Locker for 2
LK2656EK W600×D570×H1880
LK2856EK W800×D570×H1880



Locker for 4
LK4656EK W600×D570×H1880
LK4856EK W800×D570×H1880



Locker for 3
LK3956EK W900×D570×H1880



Locker for 6
LK6956EK W900×D570×H1880



BASIC COLOR

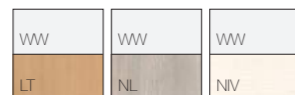

BASIC COLOR

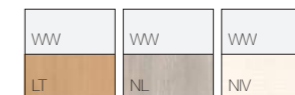

OFFICE FURNITURE

CONFERENCE TABLE

HARMONY series

Harmony Series

N WOOD
공간과 가구 엔우드

OFFICE

Conference space for harmony
Harmony is designed to be a smarter and more advanced conference. The stylish lower leg design and the endless connection structure create a simple connection table, while the ABS front cover enhances the meeting room.

CONFERENCE TABLE

HARMONY series





CONFERENCE TABLE

Stand-alone (Starter)

- CCTX080 W800×D600×H720
- CCTX010 W1000×D600×H720
- CCTX012 W1200×D600×H720
- CCTX014 W1400×D600×H720
- CCTX016 W1600×D600×H720



Adder

- CCTX012A W1240×D600×H720
- CCTX014A W1440×D600×H720
- CCTX016A W1640×D600×H720



Ender

- CCTX012S W1200×D600×H720
- CCTX014S W1400×D600×H720
- CCTX016S W1600 D600 H720



Corner Table

- CCTX700 W740×D700×H720



Corner Table

- CTX700 W700×D700×H720

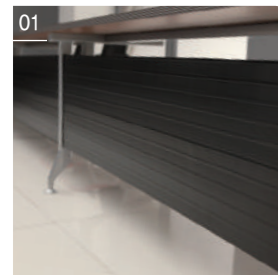

Starter (Stand-alone)

Adder

Ender



Endless type

LAYOUT

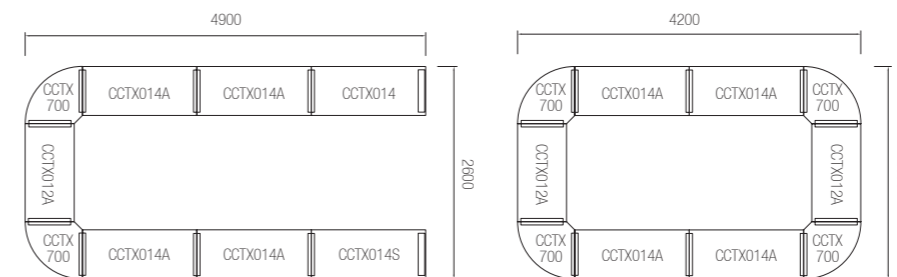

DETAIL

01_ Modesty cover

Stylish front panel with luxurious black color and line pattern.

02_ Stylish Lower Legs

The slender legs with soft curves add a touch of sophistication.

BASIC COLOR

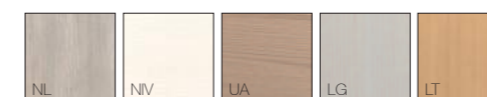



CONFERENCE TABLE

Conference Table
CCT080 W800×D600×H720
CCT012 W1200×D600×H720
CCT014 W1400×D600×H720
CCT016 W1600×D600×H720



Corner Table
CT600 W600×D600×H720



LAYOUT

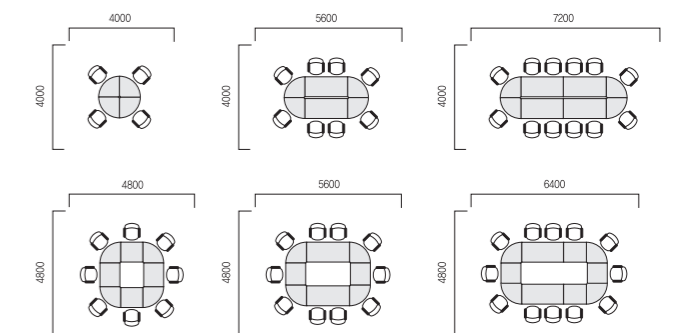

BASIC COLOR

LT	UA	MB	LG
SW	SW	SW	SW



CONFERENCE TABLE

Conference Table
CTX032 W3200×D1200×H720



Conference Table
CTX018 W1800×D900×H720
CTX024 W2400×D1200×H720



Conference Table
RCT290 Ø900×H720
RCT210 Ø1050×H720



DETAIL

01_ Stylish Leg
 The slender legs with soft curves add a touch of sophistication.

02_ Multi Wiring Cover
 The large space allows for convenient and neat wiring management and convenient vertical wiring.

03_ Round Hoof
 Flexible hoof keeps you level, even on uneven floors.



BASIC COLOR

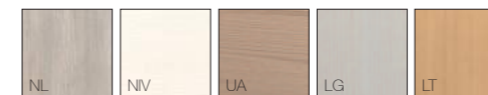



CONFERENCE TABLE

CTR030 W3000×D1200×H720
CTR036 W3600×D1200×H720
CTR048 W4800×D1200×H720



CTR018 W1800×D900×H720
CTR021 W2100×D900×H720
CTR024 W2400×D1200×H720



RCT190 Ø900×H720
RCT110 Ø1050×H720



BASIC COLOR





CONFERENCE TABLE

- CT015 W1500×D900×H720
- CT018 W1800×D900×H720
- CT021 W2100×D900×H720
- CT024 W2400×D1200×H720



- Round Table
 RCT090 Ø900×H720
 RCT010 Ø1050×H720



CONFERENCE TABLE

- Dining Table
 DCT012 W1200×D800×H720
 DCT014 W1400×D800×H720
 DCT016 W1600×D800×H720
 DCT018 W1800×D800×H720

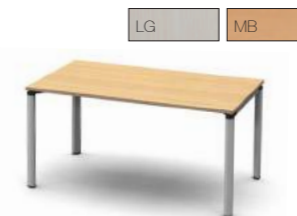

- Round Table
 MSLT007 Ø700×630~1050



※ 2 Color Top Panel (HPM)

BASIC COLOR

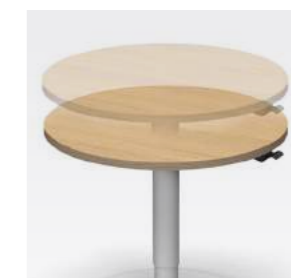
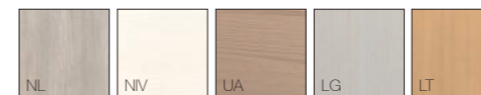

Height Adjustable Top Panel
 Manual Gas Cylinder Type

BASIC COLOR





PARTITION

Partition system that can be customized to any office space according to the nature and structure of work. It is a new space-creation system that can be installed as you want because it is rugged and has various colors and sizes.

30T SCAPE Series	136
60T BLOCK Series 유리드	140
60T BLOCK Series 엠비	142
45T BLOCK Series FX2	144

PARTITION

30T SCAPE series

Scape Series



Simple and modern design, excellent space utilization Structure that can be modified in various layouts

Lightweight panel saves space with reduced volume and is a sleek, lightweight light panel that is easy to install and transfer

30T SCAPE series

ONE POST system

By using a single post, L-, T-, and X-type panels can be connected to reduce assembly time, thereby reducing costs. Also, when connecting panels of different heights, we have the convenience of connecting panels of all heights with one of the highest size posts.



DETAIL

01_ Swivel Bracket (for Scape Board)

Swivel brackets enable various angles of layout, allowing for free space changes.

02, 03_ Various accessories

The accessories can be used to attach writing utensils, memos, etc., using the grooves on the top of the panel for convenient use of various office supplies.

04_ Leveling Feet

A plastic injection leveler is attached to the bottom to enhance design completion, and the panel can be easily adjusted horizontally without uneven flooring.

05, 06_ Two Color Edges and Posts Two color edges to choose from, combined with the fabric for a light space.

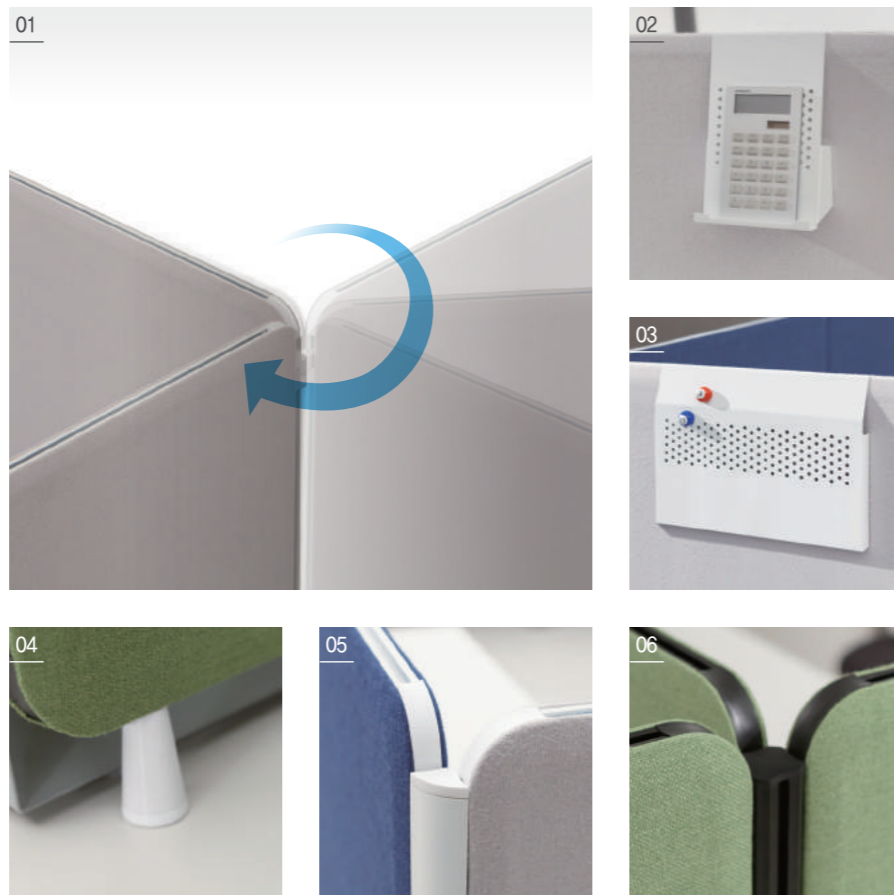

SCAPE PANEL(STEEL)

- H:1200
- PSC1062 W600
- PSC1072 W700
- PSC1082 W800
- PSC1102 W1000
- PSC1122 W1200



SCAPE PANEL(BOARD)

- H:1200
- PSC0062 W600
- PSC0072 W700
- PSC0082 W800
- PSC0102 W1000
- PSC0122 W1200



- H:1500
- PSC0065 W600
- PSC0075 W700
- PSC0085 W800
- PSC0105 W1000
- PSC0125 W1200



PANEL

POST

- 2 Way Connecting Post
- PSC6002 W26.5×D26.5×H1065



- 3 Way Connecting Post
- PSC6022 W32×D32×H1065



STABILIZER

- Stabilizer (Caster)
- PSC9110 W380×D40×H119



- Stabilizer (Fixed)
- PSC9100 W380×D40×H119



ACCESSORY

- Accessory Board
- PSC9201 W302×D12×H263

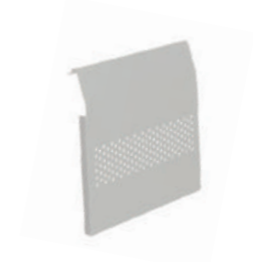

- Accessory Standing
- PSC9202 W150×D95×H227



60T BLOCK series

U-Lead Series

PANEL U-Lead 60T Basic

Basic (H970)
ULNTT-1070 W700×T60×H970
ULNTT-1080 W800×T60×H970
ULNTT-1012 W1200×T60×H970



Basic (H1160)
ULNTT-1260 W600×T60×H1160
ULNTT-1270 W700×T60×H1160
ULNTT-1280 W800×T60×H1160
ULNTT-1290 W900×T60×H1160
ULNTT-1212 W1200×T60×H1160



PANEL U-Lead 60T Upper Glass

Upper Glass (H1160)
ULGTT-1290 W900×T60×H1160
ULGTT-1212 W1200×T60×H1160



Upper Glass (H1545)
ULGTT-1580 W800×T60×H1545
ULGTT-1512 W1200×T60×H1545



Upper Glass (H1865)
ULGTT-1880 W800×T60×H1865
ULGTT-1812 W1200×T60×H1865



PANEL U-Lead 60T Grill

Single Sided Grill (H1160)
ULNBT-1260 W600×T60×H1160
ULNBT-1280 W800×T60×H1160
ULNBT-1290 W900×T60×H1160
ULNBT-1212 W1200×T60×H1160



Single Sided Grill (H1865)
ULNBT-1812 W1200×T60×H1865



Double Sided Grill (H1160)
ULNBB-1280 W800×T60×H1160
ULNBB-1290 W900×T60×H1160
ULNBB-1212 W1200×T60×H1160



Double Sided Grill w/ Upper Glass (H1160)
ULGBB-1880 W800×T60×H1865
ULGBB-1812 W1200×T60×H1865



PANEL U-Lead 60T Belt Line

Belt Line (H1092)
RSNBT-1160 W600×T60×H1092
RSNBT-1180 W800×T60×H1092
RSNBT-1112 W1200×T60×H1092



Belt Line (H1160)
RSNBT-1260 W600×T60×H1220
RSNBT-1270 W700×T60×H1220
RSNBT-1280 W800×T60×H1220
RSNBT-1290 W900×T60×H1220
RSNBT-1212 W1200×T60×H1220



Belt Line (H1540)
RSNBT-1580 W800×T60×H1540
RSNBT-1590 W900×T60×H1540
RSNBT-1512 W1200×T60×H1540



Belt Line (H1860)
RSNBT-1860 W600×T60×H1860
RSNBT-1880 W800×T60×H1860
RSNBT-1812 W1200×T60×H1860



ACCESSORY

Stabilizer
UL6LG W340×T110×H120



Post
UL60P-1000 W60×D60×H946
UL60P-1200 W60×D60×H1138



End bar
UL60PE-1000 W60×D25×H946
UL60PE-1200 W60×D25×H1138



Wiring Belt
RS-MT-700 W700×D50×H185
RS-MT-800 W800×D50×H185
RS-MT-900 W900×D50×H185
RS-MT-1200 W1200×D50×H185



BASIC COLOR



60T BLOCK series

MB Series

PANEL MB 60T Basic

Basic (1028)
RSNTT-1060 W600×T60×H1028
RSNTT-1070 W700×T60×H1028
RSNTT-1012 W1200×T60×H1028



Basic (H1092)
RSNTT-1160 W600×T60×H1092
RSNTT-1170 W700×T60×H1092
RSNTT-11801 W800×T60×H1092
RSNTT-11901 W900×T60×H1092
RSNTT-11121 W1200×T60×H1092



Basic (H1220)
RSNTT-1260 W600×T60×H1220
RSNTT-1280 W800×T60×H1220
RSNTT-1290 W900×T60×H1220
RSNTT-1212 W1200×T60×H1220



Basic (H1540)
RSNTT-1580 W800×T60×H1540



Basic (H1860)
RSNTT-1880 W800×T60×H1860
RSNTT-1890 W900×T60×H1860



PANEL MB 60T Upper Glass

Upper Glass (H1220)
RSNTT-1290 W800×T60×H1220
RSNTT-1212 W1200×T60×H1220



Upper Glass (H1540)
RSGTT-1560 W600×T60×H1540
RSGTT-1580 W800×T60×H1540
RSGTT-1590 W900×T60×H1540
RSGTT-1512 W1200×T60×H1540



Upper Glass (H1860)
RSGTT-1860 W600×T60×H1860
RSGTT-1890 W900×T60×H1860
RSGTT-1812 W1200×T60×H1860



PANEL MB 60T Double Sided Belt w/ Upper Glass

Double Sided Belt w/ Upper Glass (H1220)
RSGBB-1270 W700×T60×H1220
RSGBB-1280 W800×T60×H1220
RSGBB-1290 W900×T60×H1220
RSGBB-1212 W1200×T60×H1220



Double Sided Belt w/ Upper Glass (H1540)
RSGBB-1560 W600×T60×H1540
RSGBB-1570 W700×T60×H1540
RSGBB-1590 W900×T60×H1540
RSGBB-1512 W1200×T60×H1540



PANEL MB 60T Double Sided Belt

Double Sided Belt (H1028)
RSNBB-1080 W800×T60×H1028
RSNBB-1012 W1200×T60×H1028



Double Sided Belt (H1160)
RSNBB-1160 W600×T60×H1092
RSNBB-1170 W700×T60×H1092
RSNBB-1180 W800×T60×H1092
RSNBB-1190 W900×T60×H1092
RSNBB-1112 W1200×T60×H1092



Double Sided Belt (H1220)
RSNBB-1270 W700×T60×H1220
RSNBB-1290 W900×T60×H1220
RSNBB-1212 W1200×T60×H1220



Double Sided Belt (H1540)
RSNBB-1560 W600×T60×H1540
RSNBB-1580 W800×T60×H1540
RSNBB-1512 W1200×T60×H1540



Double Sided Belt (H1860)
RSNBB-1860 W600×T60×H1860
RSNBB-1870 W700×T60×H1860
RSNBB-1880 W800×T60×H1860
RSNBB-1890 W900×T60×H1860
RSNBB-1812 W1200×T60×H1860



ACCESSORY

Stabilizer
RS6LG W400×D66×H228



Wall Fixing Bracket
RSCT W134×D87×H23



Post
RS60P-1074 W60×D60×H1074
RS60P-1010 W60×D60×H1010
RS60P-1202 W60×D60×H1202
RS60P-1522 W60×D60×H1522
RS60P-1842 W60×D60×H1842



End bar
RS6PE-1074 W60×D23×H1074
RS6PE-1010 W60×D23×H1010
RS6PE-1202 W60×D23×H1202
RS6PE-1522 W60×D23×H1522
RS6PE-1842 W60×D23×H1842



Wiring Belt
RSMS-600 W589×D120×H35
RSMS-700 W689×D120×H35
RSMS-800 W789×D120×H35
RSMS-900 W889×D120×H35
RSMS-1200 W1189×D120×H35



45T BLOCK series

FX2 Series

PANEL 45T Basic

Basic

- MF2-10306 W600×D45×H1030
- MF2-10307 W700×D45×H1030
- MF2-10308 W800×D45×H1030
- MF2-103010 W1000×D45×H1030
- MF2-103012 W1200×D 45×H1030



Basic

- MF2-11606 W600×D45×H1160
- MF2-11607 W700×D45×H1160
- MF2-11608 W800×D45×H1160
- MF2-116010 W1000×D45×H1160
- MF2-116012 W1200×D45×H1160



Basic

- MF2-14606 W600×D45×H1460
- MF2-14607 W700×D45×H1460
- MF2-14608 W800×D45×H1460
- MF2-146010 W1000×D45×H1460
- MF2-146012 W1200×D45×H1460



Basic

- MF2-17606 W600×D45×H1760
- MF2-17607 W700×D45×H1760
- MF2-17608 W800×D45×H1760
- MF2-176010 W1000×D45×H1760
- MF2-176012 W1200×D45×H1760



PANEL 45T Belt

Belt

- MF2B-11606 W600×D45×H1160
- MF2B-11607 W700×D45×H1160
- MF2B-11608 W800×D45×H1160
- MF2B-116010 W1000×D45×H1160
- MF2B-116012 W1200×D 45×H1160



Belt

- MF2B-14606 W600×D45×H1460
- MF2B-14607 W700×D45×H1460
- MF2B-14608 W800×D45×H1460
- MF2B-146010 W1000×D45×H1460
- MF2B-146012 W1200×D 45×H1460



PANEL 45T Multi Belt

Multi Belt

- MF2MB-11606 W600×D45×H1160
- MF2MB-11607 W700×D45×H1160
- MF2MB-11608 W800×D45×H1160
- MF2MB-116010 W1000×D45×H1160
- MF2MB-116012 W1200×D 45×H1160

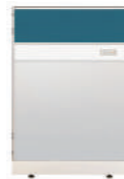

Multi Belt

- MF2MB-14606 W600×D45×H1460
- MF2MB-14607 W700×D45×H1460
- MF2MB-14608 W800×D45×H1460
- MF2MB-146010 W1000×D45×H1460
- MF2MB-146012 W1200×D 45×H1460



PANEL 45T Upper Glass

Upper Glass

- MF2G-10306 W600×D45×H1030
- MF2G-10307 W700×D45×H1030
- MF2G-10308 W800×D45×H1030
- MF2G-103010 W1000×D45×H1030
- MF2G-103012 W1200×D 45×H1030



Upper Glass

- MF2G-11606 W600×D45×H1160
- MF2G-11607 W700×D45×H1160
- MF2G-11608 W800×D45×H1160
- MF2G-116010 W1000×D45×H1160
- MF2G-116012 W1200×D45×H1160



Upper Glass

- MF2G-14606 W600×D45×H1460
- MF2G-14607 W700×D45×H1460
- MF2G-14608 W800×D45×H1460
- MF2G-146010 W1000×D45×H1460
- MF2G-146012 W1200×D45×H1460



Upper Glass

- MF2G-17606 W600×D45×H1760
- MF2G-17607 W700×D45×H1760
- MF2G-17608 W800×D45×H1760
- MF2G-176010 W1000×D45×H1760
- MF2G-176012 W1200×D45×H1760



PANEL 45T Belt w/ Upper Glass

Belt w/ Upper Glass

- MF2BG-11606 W600×D45×H1160
- MF2BG-11607 W700×D45×H1160
- MF2BG-11608 W800×D45×H1160
- MF2BG-116010 W1000×D45×H1160
- MF2BG-116012 W1200×D 45×H1160



Belt w/ Upper Glass

- MF2BG-14606 W600×D45×H1460
- MF2BG-14607 W700×D45×H1460
- MF2BG-14608 W800×D45×H1460
- MF2BG-146010 W1000×D45×H1460
- MF2BG-146012 W1200×D 45×H1460



Stabilizer

- MLE002 W400×D63×H163



Multi Outlet

- MCL3 W275×D90×H42



Post

- MF2P-1030 W45×D45×H1030
- MF2P-1160 W45×D45×H1160
- MF2P-1460 W45×D45×H1460
- MF2P-1760 W45×D45×H1760



End bar

- MF2EC-1030 W45×D10×H1030
- MF2EC-1160 W45×D10×H1160
- MF2EC-1460 W45×D10×H1460
- MF2EC-1760 W45×D10×H1760





OFFICE CHAIR

Futuristic office chair designed with new technology and new construction method. It is composed of various products that can be used anytime, anywhere, such as management, general office, meeting, lobby.

EXECUTIVE CHAIR Series 148

OFFICE CHAIR Series 152

CONFERENCE CHAIR Series 160

OFFICE CHAIR

Executive Chair that provides sophisticated elegance in a modern, slim-style - Kyle The combination of understated volume and slim edged armrests creates a luxurious yet sophisticated style. Double layered structure with inner mesh and leather on the back, and multi-limited tilting function for natural movement of the body satisfy slim style and comfortable seating at the same time.



Design for office

By diversifying the product specifications, finishing colors and materials, it offers a new direction for the leather chair through a composition that is suitable for offices and homes.

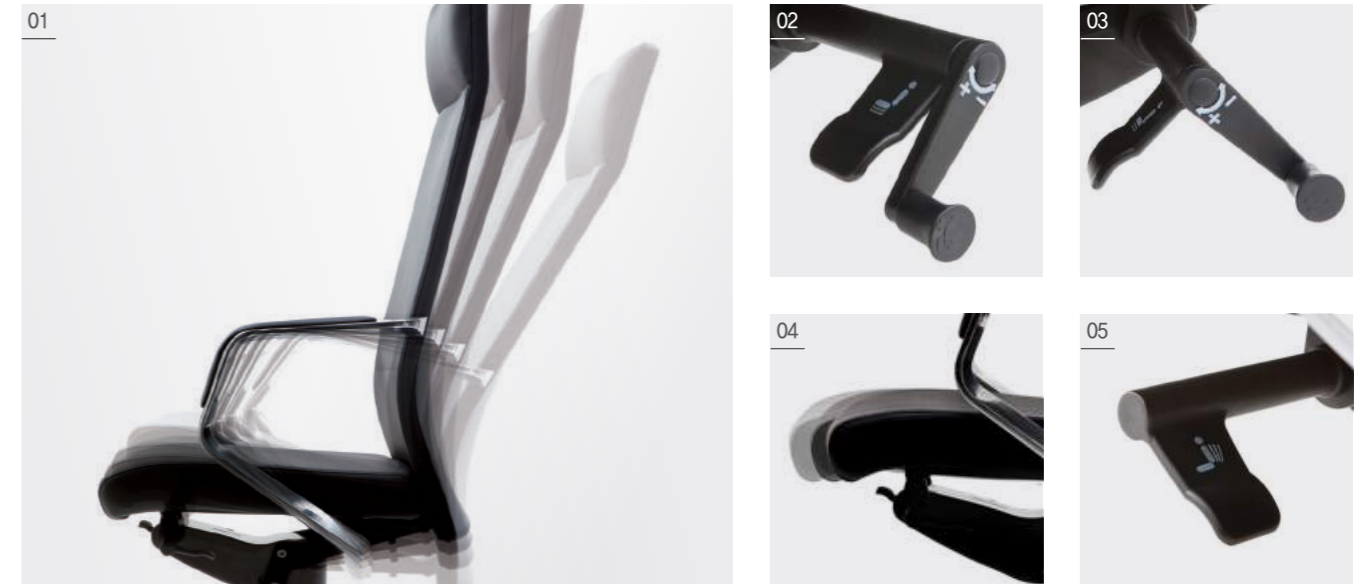

DETAIL

01_ Synchronized Tilting

At the same time, the back plate is tilted at each angle and the body is tilted backwards to extend the whole body, restoring the S position of the spine and stretching the body naturally.

02_ Seat height adjustment

The seat height can be adjusted using the handle on the bottom right of the chair. When seated, adjust the legs to be naturally perpendicular to induce a natural posture.

03_ Tilting Strength Adjustment

Different people can sit and give different strengths, so the tilting strength is adjusted to allow comfortable tilting even when the power is appropriate to the seated person.

04_ Seat Depth Control

The seat depth can be adjusted to fit the user's body, keeping the back and body of the chair tight and relieving pressure on the hips and thighs.

05_ Tilting step lock

It is a function to fix at the desired angle by using the handle on the bottom left of the chair, and it can be used to maintain the desired angle without applying force on the back by holding the back and fixing it at the desired angle.



OFFICE CHAIR
EXECUTIVE CHAIR series

Executive Chair Series

EXECUTIVE CHAIR

Executive Chair Genuine Leather
C53G11-L W597×D618×H1165/1253



Executive Chair Genuine Leather
C53G12-L W597×D615×H939/1030



Executive Chair Artificial Leather
C53G11-IL W597×D618×H1165/1253



Executive Chair Artificial Leather
C53G12-IL W597×D615×H939/1030



EXECUTIVE CHAIR

Executive Chair Genuine Leather
JPMG-101 W670×D710×H1150/1240



Executive Chair Artificial Leather
JPM-101 W670×D710×H1150/1240



Executive Chair Artificial Leather
JEXA-101 W700×D720×H1185/1255



Executive Chair Artificial Leather
JEXA-201 W680×D700×H940/1010



Executive Chair Genuine Leather
JNU-101(LT) W740×D670×H1155/1230



Executive Chair Artificial Leather
JNU-101 W740×D670×H1155/1230



Executive Chair Artificial Leather
JNUA-201 W740×D680×H1000/1070



BASIC COLOR



BLACK

CHAIR

OFFICE CHAIR
OFFICE CHAIR series

The simple design along the understated lines fills the sense of space. Experience the ultimate in comfort with our convenient features that support your body and posture.

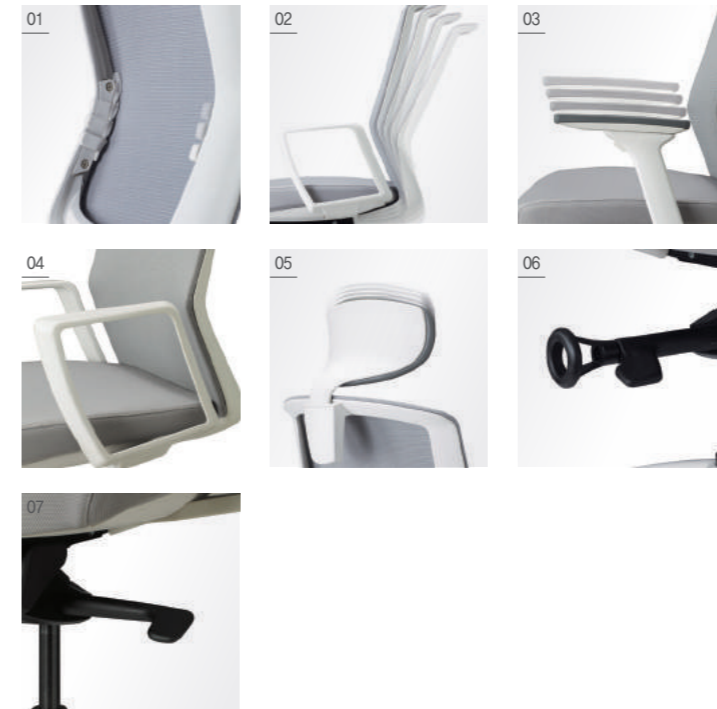

DETAIL

- 01_ Lumbar support height adjustment (elastic type)**
 You can easily adjust the elasticity of the mesh by operating the lever behind the back up and down.
- 02_ Synchronized Tilting**
 Synchronized tilting moves the back and the seat at different angles, keeping you comfortable in a variety of positions.
- 03_ Adjustable armrest**
 The adjustable armrests allow you to adjust the height, front, rear, left and right widths.
- 04_ Fixed armrest**
 The position and angle are set based on ergonomic figures for comfortable use.
- 05_ Headrest Adjustment**
 You can adjust the height to fit your body and support it comfortably with its own tension.
- 06_ Tilt Strength Adjustment**
 Back strength can be adjusted using the round dial located under the seat.
- 07_ Multi Locking**
 When flipping the back, you can adjust the angle in 3 steps using the left handle on the bottom of the seat.

OFFICE CHAIR

Office Chair
BPJ1G10L W668×D586×H1147



Office Chair
BPJ1G10M W668×D568×H976



Office Chair
BPJ1G20L W625×D586×H1147



Office Chair
BPJ1G20M W625×D568×H976



FRAME



Backrest/Seat-MESH/FABRIC

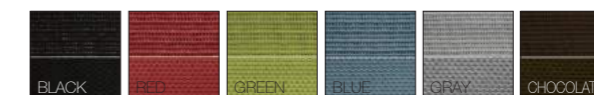

OFFICE CHAIR series

The lumbar support and tilting function comfortably support various body types. From headrests to seat depth, you can set it up for your body shape for optimum comfort.



DETAIL

01_ Lumbar support height adjustment (elastic type)
You can easily adjust the elasticity of the mesh by operating the lever behind the back up and down.

02_ Synchronized Tilting
Synchronized tilting moves the back and the seat at different angles, keeping you comfortable in a variety of positions.

03_ Adjustable armrest
The adjustable armrests allow you to adjust the height, front, rear, left and right widths.

04_ Fixed armrest
The position and angle are set based on ergonomic figures for comfortable use.

05_ Headrest Adjustment
You can adjust the height to fit your body and support it comfortably with its own tension.

06_ Seat plate
Unlike the traditional cloth finishing method, the fabric is made to replace the cloth, making it possible to change the cloth.

07_ Tilt Strength Adjustment
Back strength can be adjusted using the round dial located under the seat.

08_ Multi Locking
When flipping the back, you can adjust the angle in 3 steps using the left handle on the bottom of the seat.

OFFICE CHAIR

Office Chair
BPS27G10L W668×D596×H1139



Office Chair
BPS27G10M W668×D567×H977



Office Chair
BPS27G20L W625×D596×H1139



Office Chair
BPS27G20M W625×D567×H977



Office Chair
BPE20F10C W640×D560×H875



FRAME



Backrest-MESH



Seat-FABRIC



OFFICE CHAIR
OFFICE CHAIR series

OFFICE CHAIR

Office Chair
BPE1G10 W627×D590×H910



Office Chair
BPE1E20 W607×D590×H875



Office Chair
BPE1C10 W605×D580×H915



OFFICE CHAIR

Office Chair
BPU15F10C W605×D510×H850



Office Chair
BPU15F10V W605×D510×H850



Office Chair
BPU15F40C W520×D510×H850



Office Chair
BPU15F40V W520×D510×H850



New changes by simplicity

The balance of useful features and beautiful design creates a new change in your life. You can experience a relaxing environment with selected materials and convenient features to comfort.

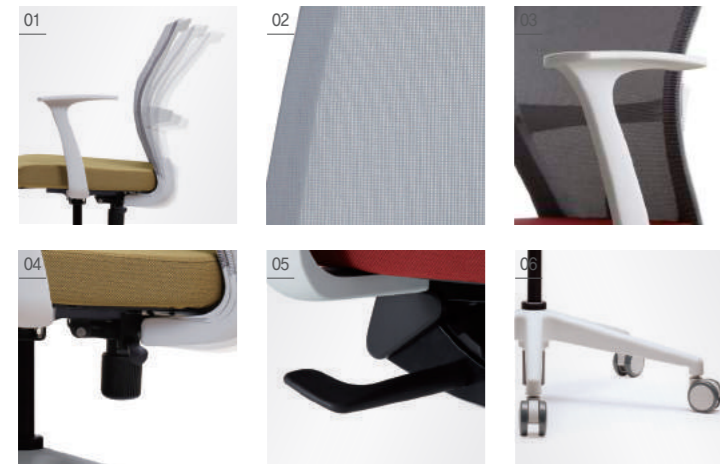

DETAIL

- 01_ Synchronized Tilting**
Synchronized tilting moves the back and the seat at different angles, keeping you comfortable in a variety of positions.
- 02_ Mesh material**
The mesh material applied to the back has excellent elasticity and maintains its optimum state without sagging.
- 03_ Fixed armrest**
The plastic fixed armrests are positioned and angled based on ergonomic figures for anyone to use comfortably.
- 04_ Tilt Strength Adjustment**
Back strength can be adjusted using the round dial located under the seat.
- 05_ Multi Locking**
When flipping the back, you can adjust the angle in 3 steps using the left handle on the bottom of the seat.
- 06_ Base & Caster**
The base supports the chair reliably and the caster prevents noise and floor scratches when moving.

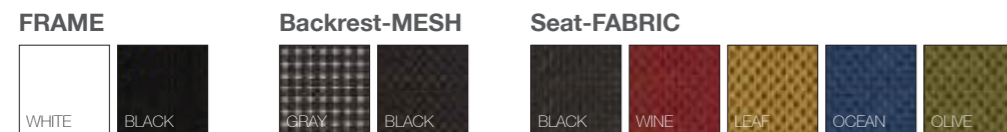

DETAIL

- 01_ Torsion bar tilting**
Tilting function that moves the back together when you lean over the torsion bar provides a softer tilting feeling.
- 02_ Mesh material**
The mesh material applied to the back has excellent elasticity and maintains its optimum state without sagging.
- 03_ Horizontal Lamination**
The folding chair can be easily loaded for easy storage and management.
- 04_ Back twist**
When leaning or moving, the whole back is twisted left and right, giving elasticity to the user's various movements.
- 05_ Urethane Caster**
Apply urethane caster that minimizes floor scratches for smooth use when rotating and moving.

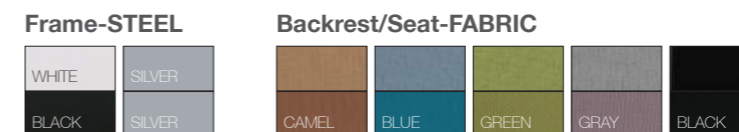

MULTI-PURPOSE CHAIR series

Simple, compact, efficient chair in square shape-cube
It is a functional chair that can be used for various purposes in a variety of spaces, allowing efficient use of space through horizontal stacking, and a tilting function that adds seating comfort to the comfortable curve of the back.
In addition, the simple style using lines and cotton and the fabric of various colors create a light space.



DETAIL

01_ Tilting function

It is a tilting function that moves the back together when you lean your body using a special material (torsion bar). The elasticity of the material is applied along with the armrest to create a comfortable working environment by providing a soft tilting feeling.

02_ Folding function

As a function that enables horizontal loading, it grabs the seat plate and raises it at right angles to fold it to the back plate to minimize the volume of the chair for efficient loading.

03_ Horizontally Stackable

After folding the seat vertically (folding function), it can be easily pushed and loaded without feeling the weight of the load to maximize space utilization and efficient storage and management.

MULTI-PURPOSE CHAIR

Multi-Purpose Chair
CG5113 W555×D545×H806



Multi-Purpose Chair
CG5113U W555×D548×H808



Multi-Purpose Chair
C5113X W482×D545×H806



Multi-Purpose Chair
C5113XU W482×D548×H808



Multi-Purpose Chair
P5143 W555×D545×H837



Multi-Purpose Chair
P5133 W555×D545×H832



Multi-Purpose Chair
P5143U W555×D548×H839



Multi-Purpose Chair
P5133U W555×D548×H834



Multi-Purpose Chair
P5143X W482×D545×H837



Multi-Purpose Chair
P5143XU W482×D548×H839



MULTI-PURPOSE CHAIR series

MULTI-PURPOSE CHAIR

Multi-Purpose Chair
JMT-M301 W615xD555xH835



Multi-Purpose Chair
JMT-M401 W510xD555xH835



Multi-Purpose Chair
JMT-M302 W615xD555xH835



Multi-Purpose Chair
JMT-402 W510xD555xH835



Multi-Purpose Chair
JMT-412 W510xD555xH835



Multi-Purpose Chair
JVK-301 W630xD580xH810



Multi-Purpose Chair
JVK-302 W630xD580xH810



Multi-Purpose Chair
JVK-401 W500xD580xH810



Multi-Purpose Chair
JVK-402 W500xD580xH810



MULTI-PURPOSE CHAIR

Multi-Purpose Chair
JX0-102 W615xD520x780~890



Multi-Purpose Chair
JHC-100(97) W390xD390x460~570



Multi-Purpose Chair
C5643U W532xD497xH783



Multi-Purpose Chair
C5643 W532xD497xH783



Multi-Purpose Chair
JEUR-100 W550xD485xH750



Multi-Purpose Chair
JX0-202 W580xD530xH780~890



Multi-Purpose Chair
JHC-500 W520xD520xH470



Multi-Purpose Chair
C5633U W510xD495xH784



Multi-Purpose Chair
C5633 W510xD495xH784



Multi-Purpose Chair
JEUR-200 W520xD515xH750





EXECUTIVE FURNITURE

Great ideas to change the world begin in great spaces. N wood's executive furniture represents the high-class position of the global leader with solid design and high-quality materials, and actively supports successful business through work efficiency with various functionalities and storage systems.

GENERAL Series	164
MATE Series	172
TONO Series	178
MAJESTY Series	190
EFFORT Series	196

EXECUTIVE FURNITURE



The General Series is a combination of natural veneer and color boards that create a refined and luxurious look.

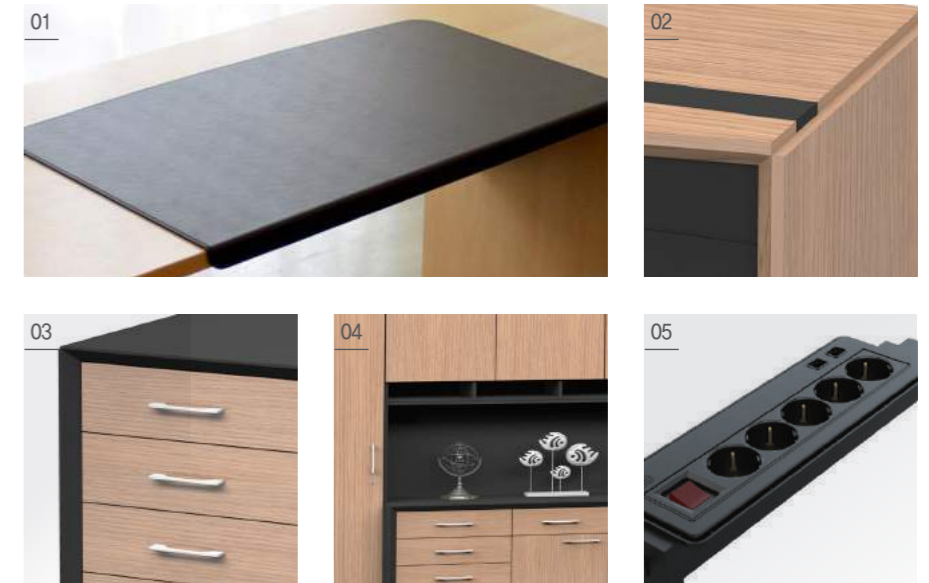

Design for office

**DETAIL****01_ Luxury leather pad**

A premium leather pad finish on the main work surface of the desk provides excellent touch when used.

02_ Top plate, Side plate 45 degree cutting structure 45-degree cutting structure enhances luxury and profoundness

03_ Damping Rail

Damping function prevents damage to the product by preventing noise and smoothly opening and closing structure.

04_ Motion detection sensor light

It is convenient because the sensor detects the movement and lights up

05_ Multi-outlet

Multi-tap and LAN porter are built in on the top of the desk to keep the wiring neat.

DESK

Desk
GED021W W2100xD1000xH750



Side Desk
GESD014W W1400xD600xH750



DRAWER

Mobile Pedestal
GEDP003W W500xD620xH610



Mobile Pedestal
GEDP004W W500xD620xH610



CREDENZA

Credenza
GECA121W W2100xD600xH750



CABINET

Cabinet
GEBS084GHW W800xD420xH1900



Cabinet
GEBS084GW W800xD420xH1900



Cabinet
GEGB064W W600xD420xH1900



Wardrobe
GELK064W W600xD420xH1900

Stack on Hutch
GEHCB021W W2100xD420xH1150



CABINET SET



Cabinet Set 1
GELK064W + GECA121W + GEGB064W + GEHCB021W
 W3300xD600xH1900



Cabinet Set 2
GELK064W + GECA121W + GEGB064W
 W3300xD600xH1900



Cabinet Set 3
GELK064W GEBS084GW + GEGB064W
 W2800xD420xH1900



Cabinet Set 4
GELK064W + GEBS084GHW + GEGB064W
 W2800xD420xH1900

BASIC COLOR

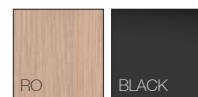

BASIC COLOR

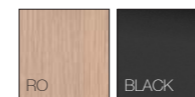



SOFA TABLE

Sofa Table
GEGT016W W1600×D700×H450



End Table
GEGT057W W520×D700×H480



SOFA

Single Sofa
UBF-S34 W1000×D860×H650



Sofa for 3
UBF-S35 W2000×D860×H650



DESK

Electric Height Adjustable Desk
GEMSD012W W1200×D600×H680~1200
GEMSD014W W1400×D600×H680~1200



CONFERENCE TABLE

Conference Table
GECT024CW W2400×D1200×H750



Conference Table
GECT036CW W3600×D1200×H750



BASIC COLOR

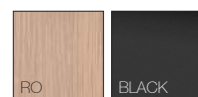

Natural veneer in the image may differ from actual colors.



50dB / less motor running sound



20,000 times self endurance test



Standby power less than 0.1W Controller system



Rollback function in vertical operation



120Kg Loading Capacity 500Kg Self Rock

EXECUTIVE FURNITURE

MATE series

Mate Series



The Mate series, designed with the combination of metal and wood, further enhances the feeling and flexibility.



Design for office



DETAIL

- 01_ Birch tops**
Durable birch tops feel stylish on the collar and sides
- 02_ Stylish design**
Slim legs with soft curves add a touch of refinement.
- 03_ Multi Wiring Cover**
The large space allows for convenient and neat wiring management and convenient vertical wiring.
- 04_ Round Hoof**
Flexible hoof keeps you level, even on uneven floors.

DESK

Desk
MATSD121 W2100×D2000×H750



Desk
MATD021 W2100×D900×H750



CONFERENCE TABLE

Conference Table (Wiring Duct)
MATCT024C W2400×D1100×H750



Conference Table
MATDCT024
W2400×D1100×H750



CREDENZA

Credenza
MATCA118 W1800×D400×H660



SOFA TABLE

End Table
MATGT010 W450×D650×H450



Sofa Table
MATGT016 W1600×D600×H450



SOFA

Single Sofa
URO-S61 W870×D840×H710



Sofa for 3
URO-S62 W2020×D840×H710



BASIC COLOR



CABINET

Cabinet
MATCB084 W800×D400×H1600



Cabinet
MATCB064 W600×D400×H1600



Cabinet
MATBS084G W800×D400×H1600



Wardrobe
MATLK164 W600×D400×H1600



DETAIL

1_ Damping rail
Damping function prevents damage to the product by preventing noise and smoothly opening and closing structure.

02_ Leveling Feet
Leveling feet with simple design

BASIC COLOR





Tono's sensational design is designed to handle tasks smoothly by combining multiple units, especially in accordance with the size of the work space.



Design for office



DETAIL

01_ Side round top

The circular design combined with the straight line is useful for meetings.

02_ Damping Rail

Damping function prevents damage to the product by preventing noise and smoothly opening and closing structure.

03_ Leather Pad

A leather pad finish on the main work surface of the desk provides excellent touch.

DESK

Desk
TOD022F W2200×D1080×H750



Desk
TOD018 W1800×D800×H750
TOD020 W2000×D800×H750



Desk
TODD119F W1900×D900×H750
TODD121F W2100×D900×H750

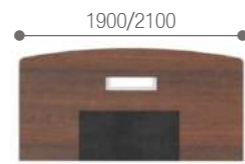

SIDE DESK

Side Desk
TOSD012 W1200×D600×H750
TOSD014 W1400×D600×H750



Side desk
TOSDP010 W1000×D1100×H750



BASIC COLOR

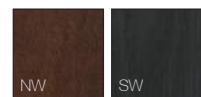

STORAGE

2 Drawer Filing (Fixing)
TODP002FF W403×D560×H720



2 Drawer Filing (Mobile)
TODP102FF W403×D560×H695



3 Drawer (Fixing)
TODP003F W403×D560×H720



3 Drawer Filing (Mobile)
TODP103F W403×D560×H695



BASIC COLOR





BOOKSHELF

CABINET

BOOKSHELF

BOOKSHELF

CREDENZA

CABINET

CABINET

LOCKER

BOOKSHELF

CABINET

Cabinet
TOD022F W600×D420×H1900



Wardrobe
TOLK064(L/R) W600×D420×H1900



CABINET

Bookshelf
TOBS064G W600×D420×H1900



Bookshelf
TOBS0640P W600×D400×H1900



CREDENZA

Credenza
TOCA118 W1800×D500×H650



Stack on Hutch
TOHCB020 2000×420×1150
TOHCB022 2200×420×1150



Corner Bookshelf
TOCN400R W400×D400×H1900



BASIC COLOR



BASIC COLOR



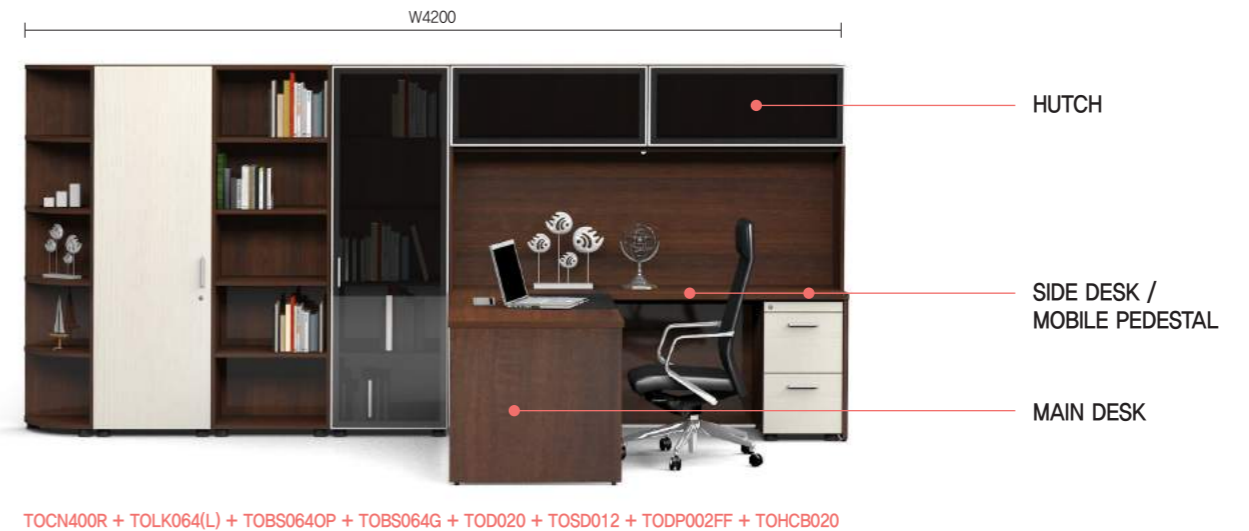
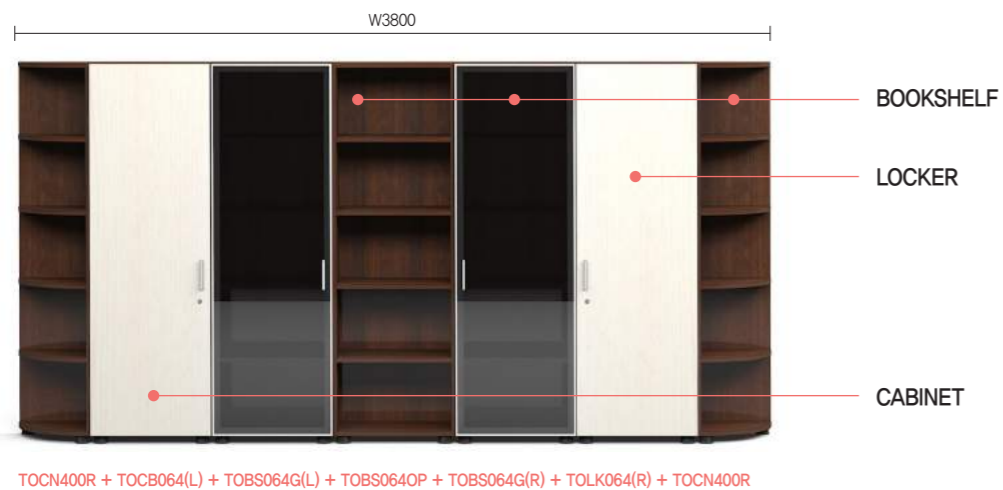
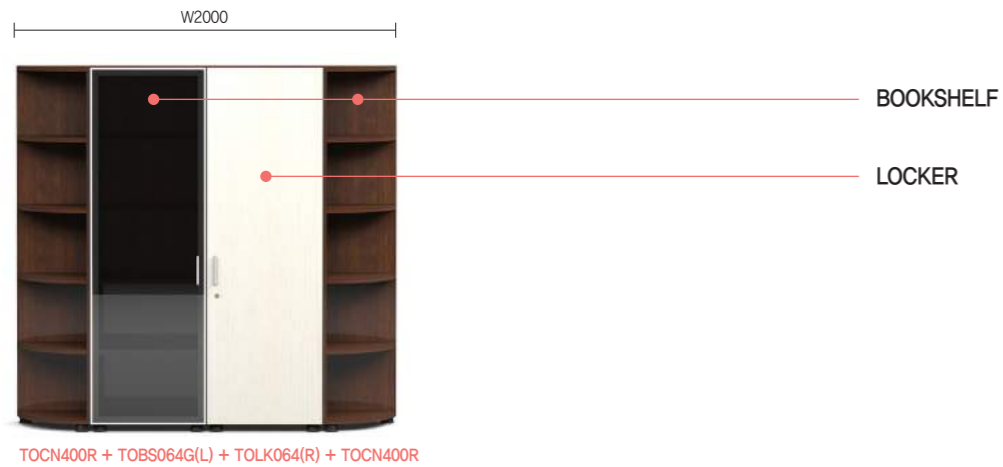

- 1** Round Corner Bookshelf - TOCN400R
Rounded bookshelf creates a soft impression.
- 2** Wardrobe - TOLK064(L)
Plenty of storage is possible in your personal wardrobe.
- 3** Bookshelf - TOBS064OP
The five-tier open bookcase enhances openness.
- 4** Bookshelf - TOBS064G
The bookcase, an all-glass door, is enhanced with black glass.
- 5** Main Desk - TOD020
Consists of W1800, 2000, easy to carry out main business
- 6** Side Desk - TOSD012
The side desk is easy to expand your workspace.
- 7** Stack on Hutch - TOHCB020
A comfortable storage space on the side desk provides comfort.
- 8** 2 Drawer Mobile Pedestal - TODP002FF

BASIC COLOR





It offers a smart, futuristic meeting environment with refined and luxurious colors, design, robust construction and a simple and convenient wiring system.



CONFERENCE TABLE

Conference Table
TOCT024 W2400xD1100xH750



Conference Table
TOCT036 W3600xD1200xH750
TOCT042 W4200xD1200xH750



Conference Table (Wiring Duct)
TOCT024C W2400xD1100xH750



Conference Table
TOCT036C W3600xD1200xH750
TOCT042C W4200xD1200xH750



SOFA TABLE

Sofa Table
TOGT016 W1600xD600xH450
TOGT018 W1800xD600xH450
TOGT021 W2100xD600xH450



End Table
TOGT010 W450xD650xH450
TOGT116 W600xD650xH450



Sofa Table
TOGT0086 W800xD600xH600
TOGT0106 W1000xD600xH600
TOGT0126 W1200xD600xH600



SOFA

Single Sofa
UBF-S39 W900xD910xH780



Sofa for 3
UBF-S40 W1970xD910xH780



BASIC COLOR



Natural veneer in the image may differ from actual colors.

EXECUTIVE FURNITURE
MAJESTY series

Majesty Series

EXECUTIVE

Majesty's design is elegant, and its design is refined by its two-tone color matching.





Design for office



DETAIL

01_ SOFT CLOSING DOOR

The door closes slowly and smoothly and quietly.

02_ DAMPING rail

It mitigates the impact when the drawer closes, reducing noise and preventing damage to the product.

03_ ONE KEY SYSTEM & ON / OFF recognition

It is convenient to lock and open all the products in the boardroom with just one key, and you can recognize the lock and the opening of the door with the ON and OFF recognition.

04_ FLEXY KEY

The flexible key handle is bent to protect the user and the product.

05_ KEY CORE Removable

Separation of the key cores allows only cores to be replaced, resulting in cost savings and convenience.

DESK

Desk
MAD018 W1800×D800×H750
MAD020 W2000×D800×H750



Side Desk
MASD012 W1200×D500×H750



DRAWER

Mobile Pedestal
MADP041 W410×D600×H600



CREDENZA

Credenza
CA118 W1800×D500×H750



CABINET

Cabinet with Door
MACB085 W800×D420×H1900



Cabinet with Half Glass Door
MABS085GH W800×D420×H1900



Cabinet with Glass Door
MABS085G W800×D420×H1900



Cabinet
MACB065 W600×D420×H1900



Wardrobe
MALK1654 W600×D420×H1900

BASIC COLOR

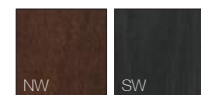

CONFERENCE TABLE

Conference Table
MACT024 W2400×D1200×H750



Conference Table
MACT032 W3200×D1200×H750



SOFA TABLE

Sofa Table
MAGT015 W1500×D700×H450
MAGT021 W2100×D700×H750



End Table
MAGT010 W450×D670×H450



BASIC COLOR

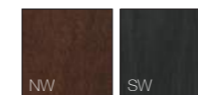

EFFORT series

Optimized for executives and important meetings, Effort is designed to create a space for the best meetings. Effort wishing success as much as we did

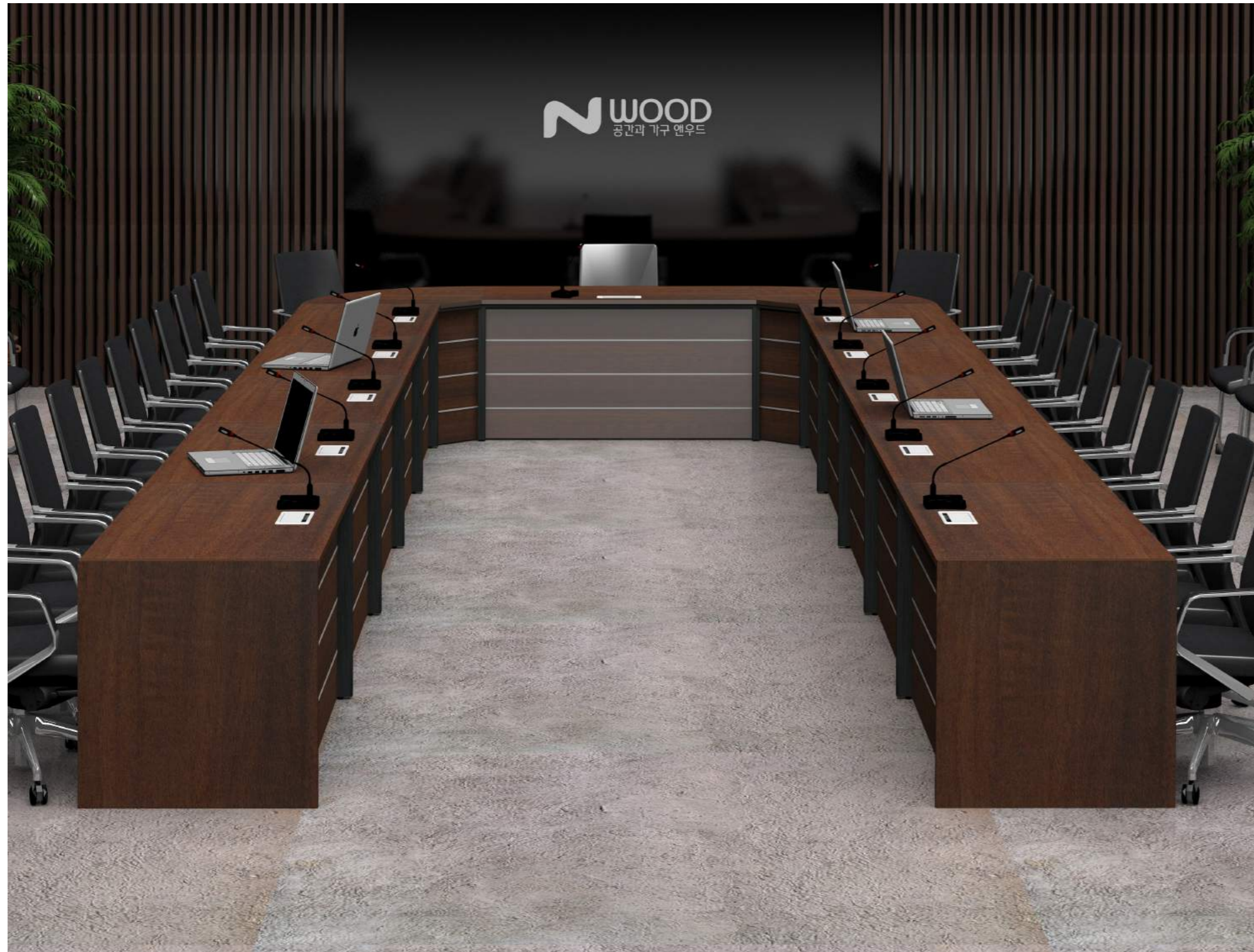

CONFERENCE TABLE

Conference Table

- MACCT080 W800×D700×H750
- MACCT012 W1200×D700×H750
- MACCT014 W1400×D700×H750
- MACCT016 W1600×D700×H750



Conference Table (Corner)

- MACT900 W900×D900×H750



End Panel

- MACT01E W760×D23×H760



LAYOUT

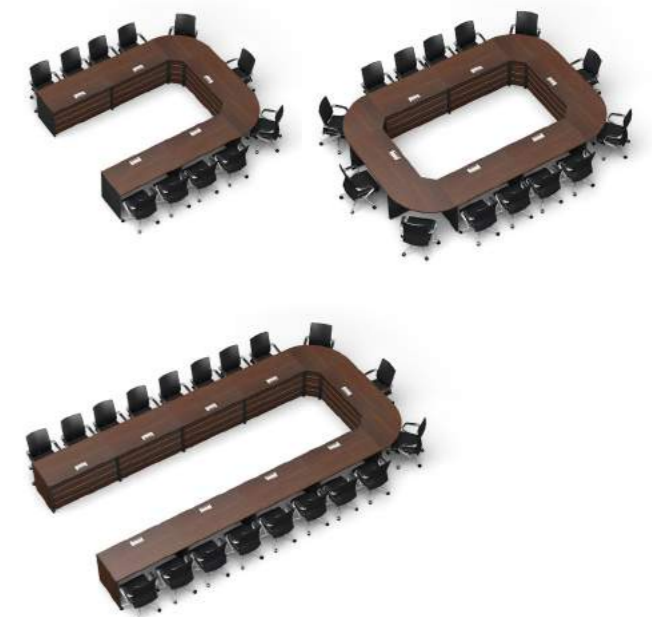

BASIC COLOR

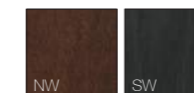

EXECUTIVE



SOFA

This sofa series is designed to enhance the dignity of creative and rational leaders and make them a communication space for important decisions.

EXECUTIVE SOFA Series	200
LOBBY SOFA Series	212

SOFA

SOFA

EXECUTIVE SOFA

The combination of luxurious artificial leather and steel material makes the sofa series perfect for any space with a clean and simple feeling. Comfortable cushioning makes you feel comfortable and safe even if you are seated for a long time.

Executive Sofa Series



SOFA
EXECUTIVE SOFA series

Executive Sofa Series



EXECUTIVE SOFA

Single Sofa
UBF-S34 W1000×D860×H650



Sofa for 3
UBF-S35 W2000×D860×H650



BASIC COLOR

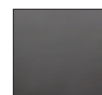

EXECUTIVE SOFA

Single Sofa
URO-S109 W720×D780×H840



Sofa for 3
URO-S110 W1980×D780×H840



BASIC COLOR

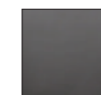



EXECUTIVE SOFA

Single Sofa
UBF-S12 W840×D900×H840



Sofa for 3
UBF-S13 W1880×D900×H840



EXECUTIVE SOFA

Single Sofa
UBF-S39 W900-D910-H780



Sofa for 3
UBF-S40 W1970-D910-H780



EXECUTIVE SOFA

Single Sofa
URO-S45 W840-D850-H910



Sofa for 3
URO-S46 W1930-D850-H910



BASIC COLOR



BASIC COLOR



SOFA
EXECUTIVE SOFA series

EXECUTIVE SOFA

Single Sofa
UBF-S43 W830-D900-H850



Sofa for 3
UBF-S44 W1950-D900-H850



Single Sofa
UBF-S37 W900-D900-H840



Sofa for 3
UBF-S38 W1910-D900-H840



Single Sofa
UBF-S41 W850-D850-H790



Sofa for 3
UBF-S42 W1850-D850-H790



Single Sofa
UBF-S45 W910-D860-H800



Sofa for 3
UBF-S46 W2010-D860-H800



BASIC COLOR



EXECUTIVE SOFA

Single Sofa
UBF-S56 W700-D770-H780



Single Sofa
URO-S61 W870-D840-H710



Single Sofa
URO-S65 W760-D720-H770



Single Sofa
URO-S70 W760-D760-H760



BASIC COLOR

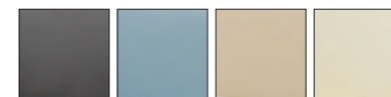

Sofa for 3
UBF-S57 W1720-D770-H780



Sofa for 3
URO-S62 W2020-D840-H710



Sofa for 3
URO-S66 W1780-D720-H770



Sofa for 3
URO-S71 W1810-D760-H760





SOFA

EXECUTIVE SOFA

Single Sofa
UBF-S61 W650-D780-H800



Sofa for 3
UBF-S62 W1900-D780-H800



BASIC COLOR



EXECUTIVE SOFA

Single Sofa
UBF-S63 W800-D820-H850



Sofa for 3
UBF-S64 W1900-D820-H850



BASIC COLOR



SOFA
EXECUTIVE SOFA series

Executive Sofa Series



SOFA

EXECUTIVE SOFA

Single Sofa
UBF-S107 W890-D840-H830



Sofa for 3
URO-S108 W1830-D840-H830



BASIC COLOR

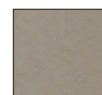

EXECUTIVE SOFA

Single Sofa
URO-S127 W730-D610-H715



Sofa for 2
URO-S128 W1250-D610-H715



Sofa for 3
URO-S129 W1750-D610-H715



BASIC COLOR



SOFA
LOBBY SOFA series

Lobby Sofa Series



LOBBY SOFA

Lobby Sofa
URO-S116 W1940-D900-H700



SOFA

LOBBY SOFA

Single Sofa
UBF-S32 W800-D640-H880



Sofa for 3
UBF-S33 W1600-D640-H880



Magazine Rack
UBF-S19 W620-D620-H420



Magazine Rack
UBF-S20 W450-D450-H420



BASIC COLOR



LOBBY SOFA

Lobby Sofa
URO-S113 W1280-D700-H800



Lobby Sofa
URO-S114 W1200-D700-H800
URO-S115 W1500-D700-H800



BASIC COLOR

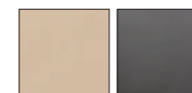

SOFA
LOBBY SOFA series

Lobby Sofa Series



LOBBY SOFA

Lounge Sofa
URO-R20 W1600-D570-H750



Lounge Sofa
URO-R20-1 W1600-D570-H750



Lounge Sofa
URO-R21 W1700-D570-H750



Lounge Sofa
URO-R22 W1500-D570-H750



BASIC COLOR



LOBBY SOFA

Lobby Sofa
URO-S103 W500-D600-H630



Lobby Sofa
URO-S101 Ø500-H350



Lobby Sofa
URO-S102 W500-D500-H350



LOBBY SOFA

Lobby Sofa
UBF-S60 W630-D630-H680



Lobby Sofa
UBF-S59 W1100-D630-H680



BASIC COLOR



SOFA

SOFA
LOBBY SOFA series

Lobby Sofa Series



SOFA

LOBBY SOFA

Lobby Sofa
URO-S118 W610-D700-H700



Lobby Sofa
URO-S118-1 W610-D700-H700



Lobby Sofa
URO-S119 W540-D700-H700



Lobby Sofa
URO-S120 W700-D700-H700



BASIC COLOR



LOBBY SOFA

Lobby Sofa
UBF-S7 W640-D640-H410



Lobby Sofa
UBF-S8 W700-D650-H790



Lobby Sofa
UBF-S9 W1230-D640-H770



Lobby Sofa
UBF-S10 W1230-D640-H770



BASIC COLOR

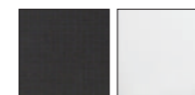

SOFA
LOBBY SOFA series

LOBBY SOFA

Lobby Sofa
UBF-S68 W600-D660-H720



Lobby Sofa
UBF-S69 W1000-D660-H720



Lobby Sofa
UBF-S70 W1500-D660-H720



Lobby Sofa
UBF-S71 W920-D660-H720



Lobby Sofa
UBF-S72 W1000-D700-H720



Lobby Sofa
UBF-S73 W660-D660-H410



Lobby Sofa
UBF-S74 W1000-D700-H720



LOBBY SOFA

Lobby Sofa
UBF-S1 W1500-D640-H740



Lobby Sofa
UBF-S2 W1000-D640-H740



Lobby Sofa
UBF-S3 W500-D640-H740



Lobby Sofa
UBF-S4 W1500-D500-H410



Lobby Sofa
UBF-S5 W1000-D500-H410



Lobby Sofa
UBF-S6 W500-D500-H410



BASIC COLOR



BASIC COLOR

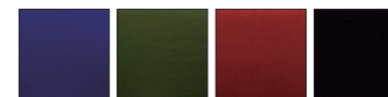

SOFA
LOBBY SOFA series

LOBBY SOFA

Lobby Sofa
URO-S104 W500-D500-H420



Lobby Sofa
URO-S121 Ø380-H430



Lobby Sofa
URO-S31 Ø710-H355



Lobby Sofa
URO-S32 W710-D670-H355



Lobby Sofa
URO-S33 W720-D715-H355



Lobby Sofa
URO-S34 W690-D500-H355



Lobby Sofa
URO-S35 W470-D510-H355



Lobby Sofa
UBF-S52 W500-D500-H300



BASIC COLOR



SOFA TABLE

Sofa Table
MAGT015 W1500×D700×H450
MAGT021 W2100×D700×H750



Sofa Table
GT012 W1200×D600×H450
GT015 W1500×D600×H450
GT018 W1800×D600×H450
GT021 W2100×D600×H450



Sofa Table
MAGT010 W450×D670×H450



Sofa Table (Glass Top)
EL001 W480-D500-H450



Sofa Table (Glass Top)
ET011 W1200-D600-H465



Sofa Table
ET040
W1200-D600-H450
W1500-D600-H450



Sofa Table
ET039
W450-D430-H510



Sofa Table
ET035 W1200-D600-H730



Sofa Table
ET038 W400-D400-H510



Sofa Table
ET036 Ø500-H550



Sofa Table
ET037 W480-D600-H570





EDUCATION FURNITURE

We offer educational furniture that can be used with peace of mind by producing educational furniture for a wide range of items, from classroom furniture to seminar furniture, laboratory rooms, and dormitory furniture.

UNIQUE Series	224
CHIC Series	228
MILD Series	232
LIBRARY Series	234
COMPUTER DESK Series	248
PERSONAL LOCKER Series	254
CLASSROOM Series	258
DORMITORY Series	264
LABORATORY Series	270
HOSPITAL Series	280

EDUCATION FURNITURE



Unique lecture table is designed with solid structure and user's convenience. It has a sleek design and is fitted with a front obstruction plate made of ABS. Convenient folding function and casters can be used efficiently.



LECTURE TABLE

Lecture Table (Urethane)
ST115PCU W1500×D500×H720
ST118PCU W1800×D500×H720



Lecture Table (Urethane)
ST115U W1500×D500×H720
ST118U W1800×D500×H720

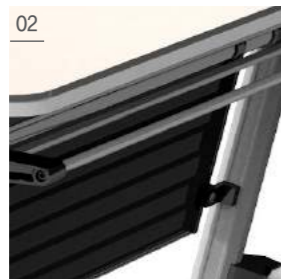
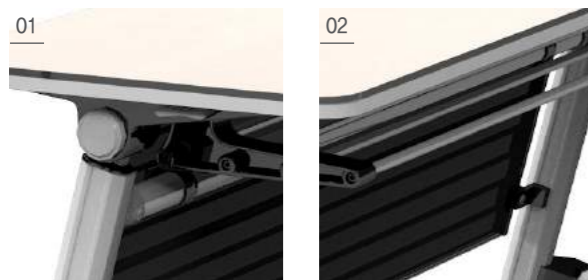

DETAIL

01_ Folding lever
The top plate can be easily folded by operating the lever attached to the side.

02_ Lower Shelf
Personal belongings etc. can be kept in consideration of user convenience.

03_ Stylish design
Dynamic legs add a modern and sophisticated image.



BASIC COLOR



URETHANE





Chic is a Lecture table made of elegant curves and softness, so it is solid and easy to fold and move.



Easily and quickly placed, the seek table is a modular table for two or three persons that can be used in various communication spaces such as training, workshops and team work.

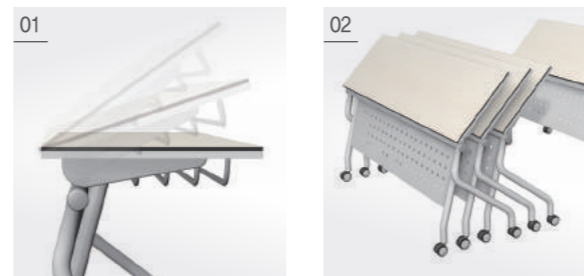

DETAIL

01_ Foldable Top Panel

If the angle of the top plate is raised horizontally and 45° as needed, it can be stacked horizontally to make efficient use of space.

02_ Horizontally Stackable

LECTURE TABLE

Lecture Table
ST015MC W1500×D450×H720
ST018MC W1800×D450×H720



Lecture Table
ST015 W1500×D450×H720
ST018 W1800×D450×H720



LECTURE TABLE

Lecture Table
PT061 W620×D490×H1105



Lecture Table
PT062 W620×D490×H1105



Lecture Table
PT051 W540×D440×H1145



Lecture Table
TT082 W800×D600×H1200



Lecture Table
TT081 W500×D450×H1200



BASIC COLOR





LECTURE TABLE

Lecture Table
STD450 W700×D525×H730
※ Urethane Top



Lecture Table
STD150 W700×D550×H1125
※ Urethane Top



Lecture Table
STD015 W1500×D550×H730
STD018 W1800×D550×H730
※ Urethane Top



Lecture Table
STD015MC W1500×D550×H730
STD018MC W1800×D550×H730
※ Urethane Top



Lecture Table
STD115 W1500×D550×H730
STD118 W1800×D550×H730
※ Urethane Top



Lecture Table
STD115MC W1500×D550×H730
STD118MC W1800×D550×H730
※ Urethane Table



DETAIL

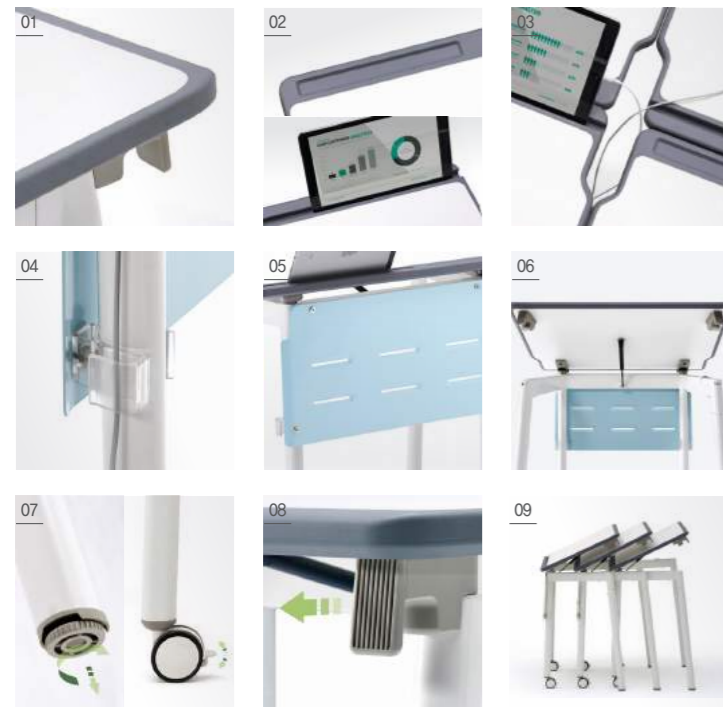

- 01_ 4-sided urethane edge**
Smooth curved urethane edge for safe use.
- 02_ Pen holder / IT device holder**
- 03_ Wiring hole design**
Combined holes allow you to organize your wiring neatly when placing opposite seats.
- 04_ Wiring Arrangement Cap**
- 05_ Front Cover Pattern & Color**
Change the atmosphere of the space with a variety of colors and patterns.
- 06_ Soft Folding Mechanism**
The hydraulic cylinder mechanism moves smoothly and flexibly when folding the table.
- 07_ Locking Casters & Gliders**
Low noise casters and glider for leveling convenience.
- 08_ Handle design**
- 09_ Horizontal Stacking**

TOP BOARD COLOR



SCREEN COLOR



FRAME COLOR





000 종류

- 010 도서, 서적
- 020 문헌정보학
- 030 배서편
- 040 장난감, 놀이, 인형, 인형극
- 050 일반학제, 예술, 기원
- 070 신문, 잡지, 연보
- 080 일반인문, 역사
- 090 방송자료

100 철학

- 110 형이상학
- 120 인식론, 논리, 언어학
- 130 철학의 체계
- 140 윤리
- 150 윤리철학사상
- 160 서양철학
- 170 논리학
- 180 심리학
- 190 종교철학, 도덕철학

200 종교

- 210 이교종교
- 220 불교
- 230 기독교
- 240 이슬람교
- 250 힌두교
- 260 유교
- 270 천주교, 개신교
- 280 종교철학사상
- 290 기타종교

600 예술

- 610 건축
- 620 조각, 조형
- 630 회화
- 640 서예
- 650 사진
- 660 공예
- 670 음악
- 680 연극, 무용
- 690 미술사

800 역사

- 810 선사시대
- 820 고대
- 830 중세
- 840 근세
- 850 현대
- 860 세계사
- 870 국사
- 880 민족사
- 890 기타



Library furniture, a space for storing and sharing knowledge and creating new knowledge, creates an optimal library environment that facilitates the search and use of vast and diverse forms of materials.



LEADING TABLE

Leading Table for 2
(Single Sided)
RT016S W1600xD600xH725



Leading Table for 3
(Single Sided)
RT021S W2100xD600xH725



Leading Table for 4
(Double Sided)
RT016 W1600xD1200xH725



Leading Table for 6
(Double Sided)
RT024 W2400xD1200xH725



Leading Table for 2
(Single Sided with Divider)
DRT016S W1600xD600xH1264



Leading Table for 3
(Single Sided with Divider)
DRT021S W2100xD600xH1264



Leading Table for 4
(Double Sided with Divider)
DRT016 W1600xD1200xH1264



Leading Table for 6
(Double Sided with Divider)
DRT024 W2400xD1200xH1264



BASIC COLOR



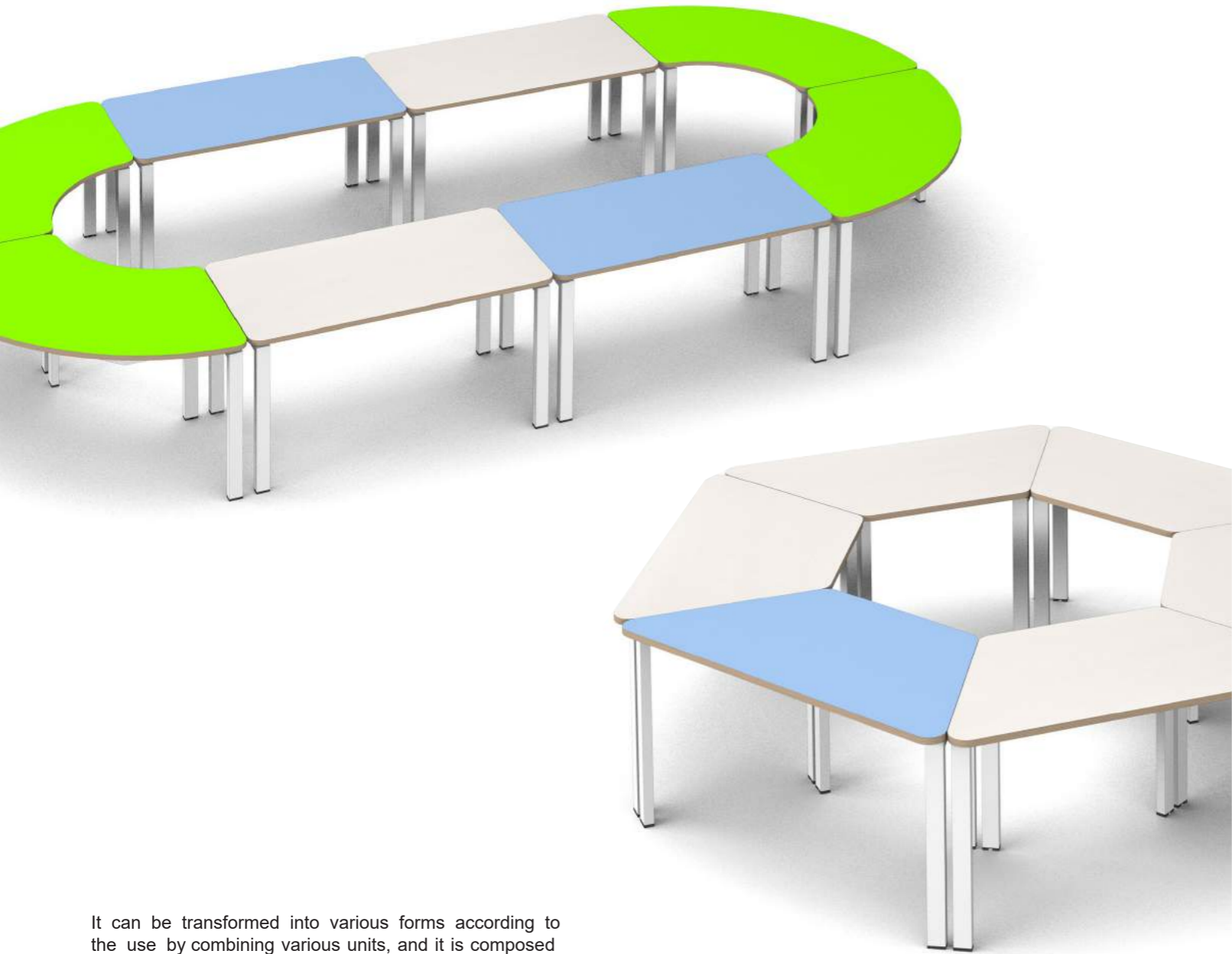

It can be transformed into various forms according to the use by combining various units, and it is composed of a system that provides various structures for group studies such as English-only classrooms and multimedia classrooms.

CONFERENCE TABLE

Conference Table
KCT012L W1200×D600×H720



Conference Table
KCT012S W1200×D600×H720



Conference Table
KCT144C W1440×D712×H720
KCT164C W1642×D757×H720



Conference Table
KCT012M W1200×D600×H720



Conference Table
KCT090R Ø900×720



LAYOUT



BASIC COLOR





BOOK SHELF

Connector

- DBS012A W305×D60×H100
- DBS022A W505×D60×H100



Connecting Pipe

- DBS002A Ø32×1000



Bookend

- DBS001A W60×D130×H210



Bookend

- DBS002A W125×H235



Signboard

- DBS011A W305×D330×H35



Signboard

- DBS021A W405×D330×H35



BOOK SHELF Single Sided

3S Single Sided (Starter)
DBS013S W965xD305xH1150



3S Single Sided (Adder)
DBS013A W910xD305xH1150



3S Single Sided (Ender)
DBS013E
W935xD305xH1150



4S Single Sided (Starter)
DBS014S W965xD305xH1500



4S Single Sided (Adder)
DBS014A W910xD305xH1500



4S Single Sided (Ender)
DBS014E
W935xD305xH1500



5S Single Sided (Starter)
DBS015S W965xD305xH1850



5S Single Sided (Adder)
DBS015A W910xD305xH1850



5S Single Sided (Ender)
DBS015E
W935xD305xH1850



6S Single Sided (Starter)
DBS016S W965xD305xH2200



6S Single Sided (Adder)
DBS016A W910xD305xH2200



6S Single Sided (Ender)
DBS016E
W935xD305xH2200



BASIC COLOR



BOOK SHELF Double Sided

3S Double Sided (Starter)
DBS023S W965xD510xH1150



3S Double Sided (Adder)
DBS023A W910xD510xH1150



3S Double Sided (Ender)
DBS023E
W935xD510xH1150



4S Double Sided (Starter)
DBS024S W965xD510xH1500



4S Double Sided (Adder)
DBS024A W910xD510xH1500



4S Double Sided (Ender)
DBS024E
W935xD510xH1500



5S Double Sided (Starter)
DBS025S W965xD510xH1850



5S Double Sided (Adder)
DBS025A W910xD510xH1850



5S Double Sided (Ender)
DBS025E
W935xD510xH1850



6S Double Sided (Starter)
DBS026S W965xD510xH2200



6S Double Sided (Adder)
DBS026A W910xD510xH2200



6S Double Sided (Ender)
DBS026E
W935xD510xH2200



BASIC COLOR





BOOK SHELF

Bookshelf
BS062 W600×D300×H800



Bookshelf
BS063 W600×D300×H1200



Bookshelf
BS064 W600×D300×H1500



Bookshelf
BS065 W600×D300×H1800



Bookshelf
BS066 W600×D300×H2100



BOOK SHELF

2S for Kids (Round)
NBS0122R W1200×D600×H800



3S for Kids (Round)
NBS0123R W1200×D600×H1200



2S for Kids
NBS102 W1000×D600×H800



3S for Kids
NBS103 W1000×D600×H1200



BOOK SHELF

Bookshelf
BS065S W640×D250×H1810



Bookshelf
BS065E W620×D250×H1810



BASIC COLOR



BASIC COLOR





The upper storage system is designed to hold textbooks, reference books and personal items, and the personal lighting allows you to concentrate on your learning.



READING TABLE

Reading Table
RT085 W820×D695×H1800

※ Task light Included



Task Light
The lighting is installed to maximize the concentration of learning, and reflects the optimal irradiation angle to prevent user glare.

PC Holder
CDC021 W250×D550×H550



Book Cart
BC010 W1050×D450×H1080



MAGAZINE SHELF

Magazine Shelf
ME093 W909×D400×H1170



Magazine Shelf
ME095 W909×D400×H1900



BASIC COLOR

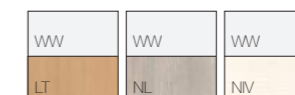



Design for office

It is a series of computer desks that can be easily installed and managed for IT devices to effectively respond to multimedia classes. It provides the best environment to maximize the effectiveness of education with special features that enhance space efficiency as well as user convenience.



DETAIL

01_ Sliding Keyboard / Mouse Tray

It can be removed only when using the keyboard / mouse tray hidden inside to create a neat and tidy computer room.

02_ PC storage box

You can safely store your PC in the box.

COMPUTER DESK series



Educational furniture system for those who dream of the future with a better educational environment with both practicality and robustness. Various layouts are supported to make reasonable use of space, and it promises optimal function and satisfaction in any space.



COMPUTER DESK

Computer Desk for 1
CD090 W900×D600×H720
CD180 W800×D600×H720



Computer Desk for 1 (Insert)
CD090M W900×D600×H720
CD180M W800×D600×H720



Computer Desk for Teacher
TCD016 W1600×D600×H720
TCD018 W1800×D700×H720



Computer Desk for 2
CD018 W1800×D600×H720
CD118 W1600×D600×H720



Computer Desk for 2 (Insert)
CD018M W1800×D600×H720
CD118M W1600×D600×H720



BASIC COLOR



COMPUTER DESK series



COMPUTER DESK

Computer Desk for 1
CD009S W900×D600×H775



Computer Desk for 2
CD018S W1800×D600×H775



EDUCATION



DETAIL

01_ PC body holder

The PC holder mounted on the bottom of the computer desk provides convenience because the height and width can be adjusted to fit the size of the PC.

02_ PC monitor fall prevention wire

Monitor Wire This system prevents the fall of PC monitor and the risk of loss.



BASIC COLOR



PERSONAL LOCKER

Locker Series



Design for office

The role of lockers to keep personal items convenient and safe has become important. Emphasis on durability and functionality, the locker will satisfy the interior effect with stable color and design.



DETAIL

01_ Lock & Name Plate

It is a handle that combines the handle function and the lock function at the same time, so students can lock the door conveniently using the lock.

02_ Leveling Feet

Even on uneven floors, the cabinet can be leveled for convenience.

PERSONAL LOCKER series

PERSONAL LOCKER

Locker for 1
SLK1414-1 W400×D400×H800
SLK1434-1 W400×D400×H1040



Locker for 2
SLK2814 W800×D400×H800
SLK2834 W800×D400×H1040



Locker for 3
SLK31214 W1200×D400×H800
SLK31234 W1200×D400×H1040



Locker for 2
SLK2414 W400×D400×H800
SLK2424 W400×D400×H1040



Locker for 4
SLK4814 W800×D400×H800
SLK4824 W800×D400×H1040



Locker for 6
SLK61214 W1200×D400×H800
SLK61224 W1200×D400×H1040



Locker for 9
SLK91224 W1200×D400×H1040



PERSONAL LOCKER

Locker for 2
SLK2454 W400×D400×H1800



Locker for 4
SLK4854 W800×D400×H1800



Locker for 3
SLK3454 W400×D400×H1800



Locker for 6
SLK6854 W800×D400×H1800



Locker for 5
SLK5464 W400×D400×H2000



Locker for 10
SLK10864 W800×D400×H2000



BASIC COLOR



BASIC COLOR

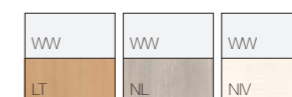



It is designed to be durable and easy to use, and provides a storage space that can be used by many people.



SHOES CABINET

Shoes Cabinet
SL0603 W600×D300×H900



Shoes Cabinet
SL0606 W600×D300×H1400



Shoes Cabinet
SL184 W800×D400×H1200



Shoes Cabinet
SL188 W800×D400×H1800



SHOES CABINET

Shoes Cabinet
SL0303SK W300×D400×H1040



Shoes Cabinet
SL0606SK W600×D400×H1040



Shoes Cabinet
SL0909SK W900×D400×H1040



BASIC COLOR



CLASSROOM series

Design for office

The role of lockers to keep personal items convenient and safe has become important. Emphasis on durability and functionality, the locker will satisfy the interior effect with stable color and design.



DETAIL

01_ Display space

Pointed to a hard shoe closet to enhance the visual impact.

02_ Leveling Feet

Even on uneven floors, the cabinet can be leveled for convenience.



SHOES CABINET

Shoes Cabinet
SL0608SK W600×D400×H1370



Shoes Cabinet
SL0610SK W600×D400×H1700

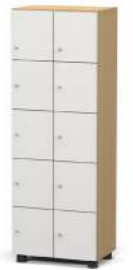

Shoes Cabinet
SL0616SKOP W600×D400×H1370



Shoes Cabinet
SL0618SKOP W600×D400×H1700



CLEANING TOOL BOX

Cleaning Tool Box
CC083 W800×D405×H1200



Cleaning Tool Box
CC085 W800×D400×H1800



BASIC COLOR

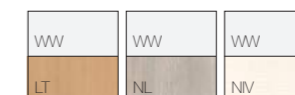

CLASSROOM series



Various teaching tools and learning equipment can be stored using the interior effect of the blackboard wall, visual stability and storage space.

BOARD CABINET

Blackboard Cabinet
CP5446 W5446×D400×H2400
 ※ Copyboard / Whiteboard sold separately



Blackboard Cabinet
CP6446 W6446×D400×H2400
 ※ Copyboard / Whiteboard sold separately



BASIC COLOR





The combination of bed, desk, and storage cabinets creates a comfortable and efficient dormitory space with convenient dormitory furniture, simple structure, reasonable space utilization, and a variety of products with a fresh design.

DORMITORY series



DETAIL

- 01_ Monitor holder / bookshelf**
Organize your desktop with a stand that holds your monitor and books.
- 02_ Adjustable Feet**
Even on uneven floors, the cabinet can be leveled for convenience.

DESK

- Desk
SQD008 W800×D700×H720
SQD010 W1000×D700×H720
SQD012 W1200×D700×H720
SQD014 W1400×D700×H720
SQD016 W1600×D700×H720
SQD018 W1800×D700×H720



- Desk
SQDBS012 W1200×D700×H1020
SQDBS014 W1400×D700×H1020
SQDBS016 W1600×D700×H1020



- Desk
BSD010 W1000×D650×H2200



- Desk
BSD112 W1200×D650×H2100



BASIC COLOR

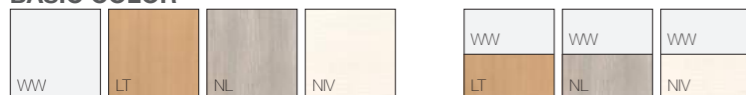

LOCKER

- Locker for 1
LK0456 W400×D570×H1880
LK0556 W500×D570×H1880



- Locker for 2
LK2856 W800×D570×H1880



- Locker for 1
LK0456DK W400×D570×H1880
LK0556DK W500×D570×H1880



- Locker for 2
LK2856DK W800×D570×H1880



- Locker for 1
LK0456EK W400×D570×H1880
LK0556EK W500×D570×H1880



- Locker for 2
LK2856EK W800×D570×H1880



- Wardrobe
LK096 W900×D600×H2000



BASIC COLOR





DETAIL

01_ Steel Frame Structure

The strong steel frame forms a skeleton, making it well-suited for dormitory due to its rugged durability and simple design.

02_ Drawer

The drawer is applied to the bottom of the bed for convenient and safe storage of small items.

BED

Bed
BD101 W2050×D1040×H760



※ Mattress sold separately
(2000×970×200)

Bed
BD101P W2050×D1040×H760



※ Mattress sold separately
(2000×970×200)

Bed
BD201P W2050×D1040×H1850



※ Mattress sold separately
(2000×970×200)

Bed
BD201 W2050×D1040×H1850



※ Mattress sold separately
(2000×970×200)



BASIC COLOR



LABORATORY series

Laboratory Series



EDUCATION

We designed and designed a space for new challenges and creations while satisfying a pleasant and safe environment in a laboratory that challenges and studies new learning that is not experienced and builds up new learning and knowledge.



EXPERIMENT TABLE

Experiment Table
LA012H W1200×D600×H800
LA014H W1400×D600×H800



Experiment Table
LA018H W1800×D600×H800



Experiment Table
LA012HD W1200×D900×H800
LA014HD W1400×D900×H800



Experiment Table
LA018HD-1 W1800×D900×H800



Experiment Table
LA018HD W1800×D900×H800
LA021HD W2100×D900×H800



DETAIL

01_ Ramis Tops
 Ramis top plate resistant to heat, chemicals and scratches

02_ Storage space
 There is plenty of storage space under the bench for convenient storage of items.

03_ Leveling feet
 Even if the floor is uneven, it can be easily leveled.

BASIC COLOR



LABORATORY series



DETAIL

01_ Inserted handle

The folding inserted aluminum handle is designed with no protruding parts, so it is safe to avoid hanging or tripping over the handle.

02_ Folding key and recognition key

The folding key, called the core, is easy to maintain due to the reflex function of the handle and the replacement of the core.

03_ Door damping hinge

The high-quality white paper with soft-closing function ensures that the door closes smoothly without the noise and impact of opening and closing the door.

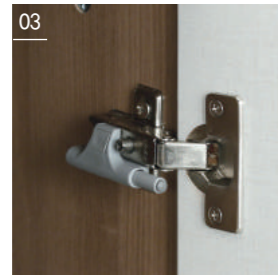

EXPERIMENT CABINET

Experiment Cabinet
LC062H W600×D600×H800



Experiment Cabinet
LC082H W800×D600×H800



Experiment Cabinet
LC063H W600×D600×H800



Experiment Cabinet
LC0122H W1200×D600×H800



Experiment Cabinet
LC1162H W1600×D600×H800



BASIC COLOR



EXPERIMENT CABINET

Experiment Cabinet
LC083 W800×D550×H1160



Experiment Cabinet
LC083G W800×D550×H1160



Experiment Cabinet
LC085 W800×D550×H1950



Experiment Cabinet
(4 Doors)
CLC085 W800×D550×H1950



Experiment Cabinet
(Half Glass Door)
LC185GH W800×D550×H1950



Experiment Cabinet
LC186GH W800×D550×H1950



Experiment Cabinet
LC086G W800×D550×H1950



Experiment Cabinet
LC186 W800×D550×H1950



Experiment Cabinet
(Stackable)
LC081H W800×D550×H400



Experiment Cabinet
(Stackable with Glass Door)
LC081GH W800 D550 H400



BASIC COLOR





SINK

Sink
LS062H W600×D600×H800



Sink
LS062HD W600×D900×H800



Sink
LS092H W900×D600×H800



Sink
LS0122H W1200×D600×H800



Sink
LS162H W1600×D600×H800

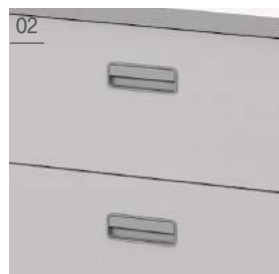

DETAIL

01_ Stainless sink & faucet
Ramis top plate resistant to heat, chemicals and scratches

02_ Inserted Handle
The folding inserted aluminum handle is designed with no protruding parts, so it is safe to avoid hanging or tripping over the handle.

03_ Ramis Top
Ramis top plate resistant to heat, chemicals and scratches

BASIC COLOR



LABORATORY series

Custom furniture system suitable for the lab. Stylish and concise with sink and separate practice system. The table top has a strong chemical resistance treatment to prevent discoloration and scratch damage and to suppress the growth of various bacteria.



EXPERIMENT TABLE

Experiment Table

- LA112H W1200×D600×H780
- LA114H W1400×D600×H780
- LA118H W1800×D600×H780



Experiment Table

- LA112HD W1200×D600×H780
- LA114HD W1400×D600×H780
- LA118HD W1800×D900×H780



Experiment Table

- LA118HDT W1800×D900×H780



BASIC COLOR



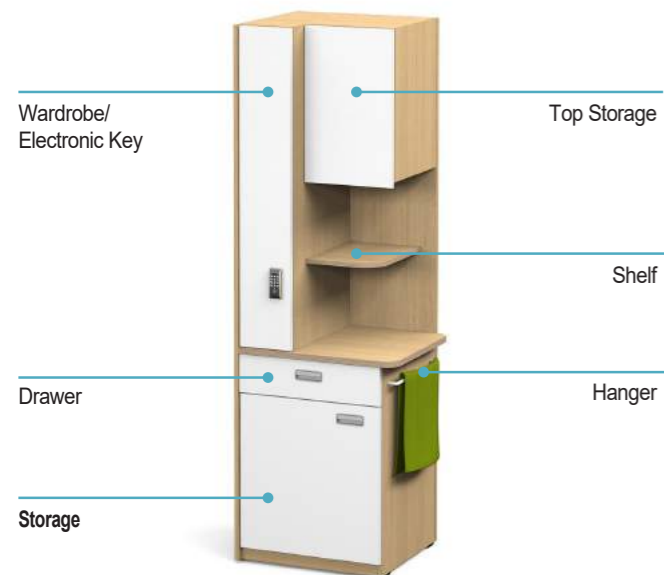

DETAIL

01_ Inserted handle
The folding, inserted aluminum handle is designed with no protrusions, so it's safe to avoid getting caught in the handle. (ON / OFF detection key allows visual confirmation of door opening)

02_ Electronic Key
Hand and key are integrated, simple design

HOSPITAL CABINET

Locker
HLK6210P(L/R) W660×D550×H2100



Locker
HLK621(L/R) W660×D550×H2100



Locker
HLK6210PEK(L/R) W660×D550×H2100



Locker
HLK621EK(L/R) W660×D550×H2100



Locker
HLK601(L/R) 600×D565×H1150



MEDICAL BED

Medical Bed
HBD019L W1900×D700×H550



BASIC COLOR



